

Model 8007  
Semiconductor Test Fixture  
Instruction Manual

Contains Operating and Servicing Information

**KEITHLEY**

# WARRANTY

Keithley Instruments, Inc. warrants this product to be free from defects in material and workmanship for a period of 1 year from date of shipment.

Keithley Instruments, Inc. warrants the following items for 90 days from the date of shipment: probes, cables, rechargeable batteries, diskettes, and documentation.

During the warranty period, we will, at our option, either repair or replace any product that proves to be defective.

To exercise this warranty, write or call your local Keithley representative, or contact Keithley headquarters in Cleveland, Ohio. You will be given prompt assistance and return instructions. Send the product, transportation prepaid, to the indicated service facility. Repairs will be made and the product returned, transportation prepaid. Repaired or replaced products are warranted for the balance of the original warranty period, or at least 90 days.

## LIMITATION OF WARRANTY

This warranty does not apply to defects resulting from product modification without Keithley's express written consent, or misuse of any product or part. This warranty also does not apply to fuses, software, non-rechargeable batteries, damage from battery leakage, or problems arising from normal wear or failure to follow instructions.

THIS WARRANTY IS IN LIEU OF ALL OTHER WARRANTIES, EXPRESSED OR IMPLIED, INCLUDING ANY IMPLIED WARRANTY OF MERCHANTABILITY OR FITNESS FOR A PARTICULAR USE. THE REMEDIES PROVIDED HEREIN ARE BUYER'S SOLE AND EXCLUSIVE REMEDIES.

NEITHER KEITHLEY INSTRUMENTS, INC. NOR ANY OF ITS EMPLOYEES SHALL BE LIABLE FOR ANY DIRECT, INDIRECT, SPECIAL, INCIDENTAL OR CONSEQUENTIAL DAMAGES ARISING OUT OF THE USE OF ITS INSTRUMENTS AND SOFTWARE EVEN IF KEITHLEY INSTRUMENTS, INC., HAS BEEN ADVISED IN ADVANCE OF THE POSSIBILITY OF SUCH DAMAGES. SUCH EXCLUDED DAMAGES SHALL INCLUDE, BUT ARE NOT LIMITED TO: COSTS OF REMOVAL AND INSTALLATION, LOSSES SUSTAINED AS THE RESULT OF INJURY TO ANY PERSON, OR DAMAGE TO PROPERTY.



Keithley Instruments, Inc. • 28775 Aurora Road • Cleveland, OH 44139 • 440-248-0400 • Fax: 440-248-6168 • <http://www.keithley.com>

**BELGIUM:**

Keithley Instruments B.V.

Bergensesteenweg 709 • B-1600 Sint-Pieters-Leeuw • 02/363 00 40 • Fax: 02/363 00 64

**CHINA:**

Keithley Instruments China

Yuan Chen Xin Building, Room 705 • 12 Yumin Road, Dewai, Madian • Beijing 100029 • 8610-62022886 • Fax: 8610-62022892

**FRANCE:**

Keithley Instruments Sarl

3, allée des Garays • 91127 Palaiseau Cedex • 01-64 53 20 20 • Fax: 01-60 11 77 26

**GERMANY:**

Keithley Instruments GmbH

Landsberger Strasse 65 • 82110 Germering • 089/84 93 07-40 • Fax: 089/84 93 07-34

**GREAT BRITAIN:**

Keithley Instruments Ltd

The Minster • 58 Portman Road • Reading, Berkshire RG30 1EA • 0118-9 57 56 66 • Fax: 0118-9 59 64 69

**INDIA:**

Keithley Instruments GmbH

Flat 2B, WILOCRISSA • 14, Rest House Crescent • Bangalore 560 001 • 91-80-509-1320/21 • Fax: 91-80-509-1322

**ITALY:**

Keithley Instruments s.r.l.

Viale S. Gimignano, 38 • 20146 Milano • 02-48 39 16 01 • Fax: 02-48 30 22 74

**NETHERLANDS:**

Keithley Instruments B.V.

Postbus 559 • 4200 AN Gorinchem • 0183-635333 • Fax: 0183-630821

**SWITZERLAND:**

Keithley Instruments SA

Kriesbachstrasse 4 • 8600 Dübendorf • 01-821 94 44 • Fax: 01-820 30 81

**TAIWAN:**

Keithley Instruments Taiwan

1 Fl. 85 Po Ai Street • Hsinchu, Taiwan, R.O.C. • 886-3572-9077 • Fax: 886-3572-903

Model 8007  
Semiconductor Test Fixture  
Instruction Manual

©1989, Keithley Instruments, Inc.  
All rights reserved.  
Cleveland, Ohio, U.S.A.  
Second Printing, October 2000  
Document Number: 8007-901-01 Rev. B

# Manual Print History

The print history shown below lists the printing dates of all Revisions and Addenda created for this manual. The Revision Level letter increases alphabetically as the manual undergoes subsequent updates. Addenda, which are released between Revisions, contain important change information that the user should incorporate immediately into the manual. Addenda are numbered sequentially. When a new Revision is created, all Addenda associated with the previous Revision of the manual are incorporated into the new Revision of the manual. Each new Revision includes a revised copy of this print history page.

Revision A (Document Number 8007-901-01) .....	January 1989
Addendum A (Document Number 8007-901-02).....	March 1989
Revision B (Document Number 8007-901-01) .....	October 2000

# SAFETY PRECAUTIONS

The following safety precautions should be observed before using the Model 8007 and the associated instruments.

This test fixture is intended for use by qualified personnel who recognize shock hazards and are familiar with the safety precautions required to avoid possible injury. Read over this manual carefully before using the test fixture.

Exercise extreme caution when a shock hazard is present at the test fixture. User-supplied lethal voltages may be present on the fixture or the connector jacks. The American National Standards Institute (ANSI) states that a shock hazard exists when voltage levels greater than 30V RMS or 42.4V peak are present. A good safety practice is to expect that hazardous voltage is present in any unknown circuit before measuring.

Inspect the connecting cables and test leads for possible wear, cracks, or breaks before each use.

For maximum safety, do not touch the test fixture, test cables or any instruments while power is applied to the circuit under test. Turn off the power and discharge any capacitors before connecting or disconnecting cables from the test fixture. Also, keep the test fixture lid closed while power is applied to the device under test. Safe operation requires the use of the lid interlock (see paragraph 2.2.1).

Do not touch any object which could provide a current path to the common side of the circuit under test or power line (earth) ground. Always make measurements with dry hands while standing on a dry, insulated surface capable of withstanding the voltage being measured.

Do not exceed the maximum signal levels of the test fixture, as defined in the specifications and operation section of this manual.

Connect the fixture  screw terminal to safety earth ground using #18 AWG or larger wire (supplied accessory).

Instrumentation and accessories should not be connected to humans.



# Safety Precautions

---

The following safety precautions should be observed before using this product and any associated instrumentation. Although some instruments and accessories would normally be used with non-hazardous voltages, there are situations where hazardous conditions may be present.

This product is intended for use by qualified personnel who recognize shock hazards and are familiar with the safety precautions required to avoid possible injury. Read the operating information carefully before using the product.

The types of product users are:

**Responsible body** is the individual or group responsible for the use and maintenance of equipment, for ensuring that the equipment is operated within its specifications and operating limits, and for ensuring that operators are adequately trained.

**Operators** use the product for its intended function. They must be trained in electrical safety procedures and proper use of the instrument. They must be protected from electric shock and contact with hazardous live circuits.

**Maintenance personnel** perform routine procedures on the product to keep it operating, for example, setting the line voltage or replacing consumable materials. Maintenance procedures are described in the manual. The procedures explicitly state if the operator may perform them. Otherwise, they should be performed only by service personnel.

**Service personnel** are trained to work on live circuits, and perform safe installations and repairs of products. Only properly trained service personnel may perform installation and service procedures.

Exercise extreme caution when a shock hazard is present. Lethal voltage may be present on cable connector jacks or test fixtures. The American National Standards Institute (ANSI) states that a shock hazard exists when voltage levels greater than 30V RMS, 42.4V peak, or 60VDC are present. **A good safety practice is to expect that hazardous voltage is present in any unknown circuit before measuring.**

Users of this product must be protected from electric shock at all times. The responsible body must ensure that users are prevented access and/or insulated from every connection point. In some cases, connections must be exposed to potential human contact. Product users in these circumstances must be trained to protect themselves from the risk of electric shock. If the circuit is capable of operating at or above 1000 volts, **no conductive part of the circuit may be exposed.**

As described in the International Electrotechnical Commission (IEC) Standard IEC 664, digital multimeter measuring circuits (e.g., Keithley Models 175A, 199, 2000, 2001, 2002, and 2010) are Installation Category II. All other instruments' signal terminals are Installation Category I and must not be connected to mains.

Do not connect switching cards directly to unlimited power circuits. They are intended to be used with impedance limited sources. NEVER connect switching cards directly to AC mains. When connecting sources to switching cards, install protective devices to limit fault current and voltage to the card.

Before operating an instrument, make sure the line cord is connected to a properly grounded power receptacle. Inspect the connecting cables, test leads, and jumpers for possible wear, cracks, or breaks before each use.

For maximum safety, do not touch the product, test cables, or any other instruments while power is applied to the circuit under test. ALWAYS remove power from the entire test system and discharge any capacitors before: connecting or disconnecting cables or jumpers, installing or removing switching cards, or making internal changes, such as installing or removing jumpers.

Do not touch any object that could provide a current path to the common side of the circuit under test or power line (earth) ground. Always make measurements with dry hands while standing on a dry, insulated surface capable of withstanding the voltage being measured.

The instrument and accessories must be used in accordance with its specifications and operating instructions or the safety of the equipment may be impaired.

Do not exceed the maximum signal levels of the instruments and accessories, as defined in the specifications and operating information, and as shown on the instrument or test fixture panels, or switching card.

When fuses are used in a product, replace with same type and rating for continued protection against fire hazard.

Chassis connections must only be used as shield connections for measuring circuits, NOT as safety earth ground connections.

If you are using a test fixture, keep the lid closed while power is applied to the device under test. Safe operation requires the use of a lid interlock.

If a  screw is present, connect it to safety earth ground using the wire recommended in the user documentation.

The  symbol on an instrument indicates that the user should refer to the operating instructions located in the manual.

The  symbol on an instrument shows that it can source or measure 1000 volts or more, including the combined effect of normal and common mode voltages. Use standard safety precautions to avoid personal contact with these voltages.

The **WARNING** heading in a manual explains dangers that might result in personal injury or death. Always read the associated information very carefully before performing the indicated procedure.

The **CAUTION** heading in a manual explains hazards that could damage the instrument. Such damage may invalidate the warranty.

Instrumentation and accessories shall not be connected to humans.

Before performing any maintenance, disconnect the line cord and all test cables.

To maintain protection from electric shock and fire, replacement components in mains circuits, including the power transformer, test leads, and input jacks, must be purchased from Keithley Instruments. Standard fuses, with applicable national safety approvals, may be used if the rating and type are the same. Other components that are not safety related may be purchased from other suppliers as long as they are equivalent to the original component. (Note that selected parts should be purchased only through Keithley Instruments to maintain accuracy and functionality of the product.) If you are unsure about the applicability of a replacement component, call a Keithley Instruments office for information.

To clean an instrument, use a damp cloth or mild, water based cleaner. Clean the exterior of the instrument only. Do not apply cleaner directly to the instrument or allow liquids to enter or spill on the instrument. Products that consist of a circuit board with no case or chassis (e.g., data acquisition board for installation into a computer) should never require cleaning if handled according to instructions. If the board becomes contaminated and operation is affected, the board should be returned to the factory for proper cleaning/servicing.



# Specifications

**DEVICE SOCKET CONFIGURATION:** 1 each, 24- and 48-pin gold contact DIP sockets (0.100 in. pin spacing, 0.300 to 0.600 in. wide, zero insertion force, replaceable).

**CONNECTOR TYPE:** 6 mass termination connectors (12 coaxial connections each, 72 total measurement pathways).

**MAXIMUM SIGNAL VOLTAGE:** 200V peak, signal or guard to any signal, guard, sub-chassis, or chassis.

**MAXIMUM SIGNAL CURRENT:** 1A peak.

**OFFSET CURRENT (18°C–28°C, <60% R.H.):** <1 pA (0.1 pA typical @ <40% R.H.).

**PATH ISOLATION (18°C –28°C, < 60% R.H.):**

Resistance: >1T $\Omega$  (10T $\Omega$  typical @ <40% R.H.).

Capacitance (nominal): 2pF.

**CROSSTALK @ 1MHz (typical):** –60dB (50 $\Omega$  source and measure).

**3 dB BANDWIDTH (typical):** 4MHz (50 $\Omega$  source and measure).

**INSERTION LOSS @ 1MHz (typical):** 0.1dB (50 $\Omega$  source and 1 M $\Omega$  measure).

**PATH RESISTANCE:** <1 $\Omega$ .

## **ENVIRONMENT:**

**Operating:** 0°C to 50°C, <80% non-condensing R.H. up to 35°C.

**Storage:** –25°C to +70°C.

## **GENERAL:**

**Socket Operating Life:** >25,000 open-close cycles.

**Lid Interlock Switching:** <28VDC, 50mA.

**Dimensions, Weight:** 140mm high x 305mm wide x 292mm deep (5.5 in. x 12 in. x 11.5 in.). Net weight 3.5kg (7 lbs., 12 oz.).

## **ACCESSORIES SUPPLIED:**

Instruction manual

Model 8007-MTC-3: 3-lug triax to mass termination connector cable assembly, 3m (10 ft.), two supplied

Model 8007-PTB: Prototyping PC board

Model 8007-GND-3: Safety grounding cable

Model 236-ILC-3: Interlock cable, 3m (10 ft.)

## **ACCESSORIES AVAILABLE:**

Model 8007-MTC-3: 3-lug triax to mass termination connector cable assembly, 3m (10ft.)

Model 8007-PTB: Prototyping PC board

Model 236-ILC-3: Interlock cable, 3m (10ft.)

Specifications are for guarded measurement configuration, including external cables.

Prices and specifications subject to change without notice.

# HOW TO USE THIS MANUAL

---

Contains information on Model 8007 features, specifications, and accessories.

## **SECTION 1** **General Information**

Outlines test fixture connections and sockets, and details how to connect the fixture to instruments for typical device tests.

## **SECTION 2** **Operation**

Contains performance verification and cleaning procedures for the test fixture, as well as interlock switch adjustment.

## **SECTION 3** **Service Information**

Lists replacement parts, and also includes component layout and schematic drawings for the Model 8007.

## **SECTION 4** **Replaceable Parts**

# Table of Contents

## SECTION 1 — General Information

1.1	INTRODUCTION .....	1-1
1.2	FEATURES .....	1-1
1.3	WARRANTY INFORMATION .....	1-1
1.4	MANUAL ADDENDA .....	1-1
1.5	SAFETY SYMBOLS AND TERMS .....	1-1
1.6	SPECIFICATIONS .....	1-2
1.7	UNPACKING AND INSPECTION .....	1-2
1.7.1	Inspection for Damage .....	1-2
1.7.2	Shipment Contents .....	1-2
1.7.3	Instruction Manual .....	1-2
1.8	REPACKING FOR SHIPMENT .....	1-2
1.9	OPTIONAL ACCESSORIES .....	1-2

## SECTION 2 — Operation

2.1	INTRODUCTION .....	2-1
2.2	FIXTURE CONFIGURATION .....	2-1
2.2.1	Rear Panel .....	2-1
2.2.2	Front Panel .....	2-5
2.2.3	Sub Chassis Guarding .....	2-6
2.3	MATRIX CARD CONNECTIONS .....	2-7
2.4	TYPICAL INSTRUMENT CONNECTIONS .....	2-7
2.4.1	Adapters .....	2-9
2.4.2	Source Measure Unit .....	2-11
2.4.3	DMM (Digital Multimeter) .....	2-11
2.4.4	Electrometer .....	2-14
2.4.5	Source Connections .....	2-14
2.5	MEASUREMENT CONSIDERATIONS .....	2-17
2.5.1	Path Isolation .....	2-17
2.5.2	Keeping Connectors and Sockets Clean .....	2-18
2.5.3	Shielding .....	2-18
2.5.4	Guarding .....	2-18
2.5.5	Cable Noise Currents .....	2-20
2.5.6	Magnetic Fields .....	2-20
2.5.7	Radio Frequency Interference .....	2-21
2.5.8	Ground Loops .....	2-21
2.5.9	Capacitance Considerations .....	2-22
2.5.10	Device Oscillation .....	2-22
2.5.11	Environmental Considerations .....	2-24
2.5.12	Vibration .....	2-24
2.5.13	Low Current and Low Voltage Measurements .....	2-24
2.5.14	Cumulative Power .....	2-24
2.5.15	AC Measurements .....	2-24

2.6	TYPICAL APPLICATIONS .....	2-25
2.6.1	CV Measurements .....	2-25
2.6.2	FET Testing .....	2-28
2.6.3	Semiconductor Parameter Analysis .....	2-29
2.7	USING THE PROTOTYPING BOARD .....	2-31
2.7.1	Board Wiring .....	2-31
2.7.2	Board Cleaning .....	2-31
2.7.3	Board Installation .....	2-32
2.7.4	Prototyping Board Considerations .....	2-32
2.7.5	Wiring Kelvin Connections on the Prototyping Board .....	2-32

### SECTION 3 — Service Information

3.1	INTRODUCTION .....	3-1
3.2	PERFORMANCE VERIFICATION .....	3-1
3.2.1	Environmental Conditions .....	3-1
3.2.2	Recommended Test Equipment .....	3-1
3.2.3	Performance Record .....	3-2
3.2.4	Isolation Resistance Verification .....	3-2
3.2.5	Offset Current Verification .....	3-4
3.2.6	Path Resistance Verification .....	3-5
3.2.7	AC Performance .....	3-6
3.3	HANDLING AND CLEANING PRECAUTIONS .....	3-7
3.3.1	Board Handling and Cleaning .....	3-8
3.3.2	Connector Cleaning .....	3-8
3.4	DISASSEMBLY .....	3-8
3.4.1	Fixture Disassembly .....	3-8
3.4.2	Sub Chassis Disassembly .....	3-9
3.5	INTERLOCK SWITCH CALIBRATION .....	3-9
3.6	PATHWAY MODIFICATION .....	3-10
3.7	BINDING POST INSTALLATION .....	3-11
3.7.1	Supplied Binding Posts .....	3-11
3.7.2	Installation Procedure .....	3-12
3.7.3	Binding Post Wiring .....	3-12
3.7.4	Sub Chassis Installation .....	3-12

### SECTION 4 — Replaceable Parts

4.1	INTRODUCTION .....	4-1
4.2	PARTS LIST .....	4-1
4.3	ORDERING INFORMATION .....	4-1
4.4	FACTORY SERVICE .....	4-1
4.5	COMPONENT LAYOUT AND SCHEMATIC DIAGRAM .....	4-1

# List of Illustrations

## SECTION 2 — Operation

Figure 2-1	Model 8007 Rear Panel .....	2-2
Figure 2-2	Safety Interlock Connections .....	2-3
Figure 2-3	Input/Output Equivalent Circuit .....	2-5
Figure 2-4	Front Panel .....	2-6
Figure 2-5	Example of Sub Chassis Guarding .....	2-7
Figure 2-6	Matrix Card Connection Example .....	2-8
Figure 2-7	Adapters Required for Connections .....	2-10
Figure 2-8	Source Measure Unit Connections .....	2-12
Figure 2-9	DMM Connections .....	2-13
Figure 2-10	Electrometer Connections .....	2-14
Figure 2-11	Voltage Source Connections .....	2-15
Figure 2-12	Current Source Connections .....	2-16
Figure 2-13	Path Isolation Resistance .....	2-17
Figure 2-14	Voltage Attenuation by Path Isolation Resistance .....	2-18
Figure 2-15	Shielding Example .....	2-19
Figure 2-16	Guarded Circuit .....	2-19
Figure 2-17	Typical Guarded Signal Connections .....	2-20
Figure 2-18	Power Line Ground Loops .....	2-21
Figure 2-19	Eliminating Ground Loops .....	2-21
Figure 2-20	Type #73 Material, Impedance vs. Frequency .....	2-23
Figure 2-21	Type #43 Material, Impedance vs. Frequency Without Leads .....	2-23
Figure 2-22	Type #43 Material, Impedance vs. Frequency With Leads .....	2-23
Figure 2-23	CV Test System .....	2-25
Figure 2-24	Typical High Frequency CV Curve Generated by Model 590 .....	2-26
Figure 2-25	Typical Quasistatic CV Curve Generated by Model 595 .....	2-27
Figure 2-26	FET Test System .....	2-28
Figure 2-27	System Connections for JFET Test .....	2-29
Figure 2-28	Typical Common-Source FET IV Characteristics .....	2-29
Figure 2-29	Semiconductor Parameter Analysis Switching System .....	2-30
Figure 2-30	Current Gain Test Configuration .....	2-31
Figure 2-31	Prototyping Board .....	2-32
Figure 2-32	Prototyping Board Installation .....	2-33
Figure 2-33	Kelvin Connections .....	2-33
Figure 2-34	Using Socket Jumpering to Add Kelvin Connections .....	2-33

## SECTION 3 — Service Information

Figure 3-1	Path Isolation Verification Connections .....	3-4
Figure 3-2	Offset Current Verification Connections .....	3-5
Figure 3-3	Path Resistance Verification Connections .....	3-6
Figure 3-4	Connections for AC Response Tests .....	3-7
Figure 3-5	Sub Chassis Removal .....	3-8
Figure 3-6	Fixture Assembly .....	3-9
Figure 3-7	Sub Chassis Disassembly .....	3-9
Figure 3-8	Hinge Alignment .....	3-10
Figure 3-9	Safety Interlock Switch Adjustment .....	3-10
Figure 3-10	Examples of Pathway Modification .....	3-11
Figure 3-11	Binding Post Installation .....	3-12

# List of Tables

## SECTION 2 — Operation

Table 2-1    Input/output Numbering ..... 2-4  
Table 2-2    Supplied Ferrite Beads..... 2-22

## SECTION 3 — Service Information

Table 3-1    Recommended Test Equipment ..... 3-2  
Table 3-2    Performance Record ..... 3-3  
Table 3-3    Supplied Binding Posts ..... 3-12

## SECTION 4 — Replaceable Parts

Table 4-1    Mass-terminated Connector Parts List ..... 4-1





# SECTION 1

## General Information

---

### 1.1 INTRODUCTION

This section contains general information about the Model 8007 Semiconductor Test Fixture, and it is arranged in the following manner:

#### 1.2 Features

#### 1.3 Warranty Information

#### 1.4 Manual Addenda

#### 1.5 Safety Symbols and Terms

#### 1.6 Specifications

#### 1.7 Unpacking and Inspection

#### 1.8 Repacking for Shipment

#### 1.9 Optional Accessories

### 1.2 FEATURES

The Model 8007 Semiconductor Test Fixture provides a convenient way to connect the Model 7072 Semiconductor Matrix Card to standard packaged semiconductor devices. The Model 8007 has two ZIF (zero insertion force) sockets to simplify connections to a variety of devices.

Key features of the Model 8007 include:

- Six mass-terminated connectors located on the rear panel for connecting the fixture to the Model 7072 matrix card or other devices.
- 24-pin and 48-pin ZIF sockets for ease of connections to a variety of DIP packaged devices from 0.3" to 0.6" lead centers.
- Prototyping board, which plugs into the ZIF sockets, can be used for custom circuit wiring.
- Guarding pathways are carried through to the ZIF socket terminals in order to maintain maximum pathway isolation.

- Hinged seamless lid for light-tight and shielded measurements.
- Interlocked lid for safety.

### 1.3 WARRANTY INFORMATION

Warranty information is located on the inside front cover of this instruction manual. Should your Model 8007 require warranty service, contact the Keithley representative or authorized repair facility in your area for further information. When returning the fixture for repair, be sure to fill out and include the service form at the back of this manual in order to provide the repair facility with the necessary information.

### 1.4 MANUAL ADDENDA

Any improvements or changes concerning the test fixture or manual will be explained in an addendum included with the unit. Be sure to note these changes and incorporate them into the manual before using or servicing the fixture.

### 1.5 SAFETY SYMBOLS AND TERMS

The following symbols and terms may be found on an instrument or used in this manual.

The  symbol on an instrument indicates that the user should refer to the operating instructions located in the instruction manual.

The  symbol represents a protective grounding terminal. This terminal must be connected to a safety earth ground via #18 AWG minimum wire before operation.

The **WARNING** heading used in this manual explains dangers that might result in personal injury or death. Always read the associated information very carefully before performing the indicated procedure.

The **CAUTION** heading used in this manual explains hazards that could damage the unit. Such damage may invalidate the warranty.

## **1.6 SPECIFICATIONS**

Model 8007 specifications may be found at the front of this manual.

## **1.7 UNPACKING AND INSPECTION**

### **1.7.1 Inspection for Damage**

Upon receiving the Model 8007, carefully unpack it from its shipping carton and inspect the fixture for any obvious signs of physical damage. Report any such damage to the shipping agent immediately. Save the original packing carton for possible future reshipment.

### **1.7.2 Shipment Contents**

The following items are included with every Model 8007 order:

- Model 8007 Semiconductor Test Fixture
- Model 8007-PTB prototyping board
- Two Model 8007-MTC-3 mass-terminated triax cable assemblies
- Safety grounding cable (Model 8007-GND-3)
- Safety interlock cable (Model 236-ILC-3)
- Five 5-way binding posts
- 24 ferrite beads for device oscillation control (see paragraph 2.5.10).
- Model 8007 Instruction Manual
- Additional accessories as ordered

### **1.7.3 Instruction Manual**

If an additional instruction manual is required, order the manual package, Keithley part number 8007-901-00. The manual package includes an instruction manual and any pertinent addenda.

## **1.8 REPACKING FOR SHIPMENT**

Should it become necessary to return the Model 8007 for repair, carefully pack the unit in its original packing carton or the equivalent, and include the following information:

- Advise as to the warranty status of the test fixture.
- Write **ATTENTION REPAIR DEPARTMENT** on the shipping label.
- Fill out and include the service form located at the back of this manual.

## **1.9 OPTIONAL ACCESSORIES**

**Model 236-ILC-3 Interlock Cable:** The Model 236-ILC-3 is 3m (10 ft.) in length and is intended to connect the Model 8007 interlock to instruments with similar interlock circuits such as the Model 236 and 237 Source Measure Units.

**Model 8007-MTC-3 Triax Cable Assembly:** The Model 8007-MTC-3 is intended for input/output connections to the Model 8007. The Model 8007-MTC-3 has twelve 3-meter (10-foot) triaxial cables that terminate to a single mass-terminated connector on one end, and each cable is terminated with a male triax connector on the other end. A total of six Model 8007-MTC-3 cable assemblies are required to use all 72 input/output pathways on the test fixture.

**Model 8007-PTB Prototyping Board:** The Model 8007-PTB Prototyping board is the board supplied with the Model 8007. Additional Model 8007-PTB boards may be ordered to allow ease of changing test circuits. The prototyping board contains breadboarding areas with holes on standard 0.1" centers, 0.04" in diameter for easy mounting of standard components such as ICs, transistors, diodes, resistors, and capacitors. The Model 8007-PTB plugs into the two ZIF sockets located on the top panel of the test fixture. The prototyping board can be secured to the top panel with the captive screw, if desired, or it can be left unsecured for ease of removal.

# SECTION 2

## Operation

---

### 2.1 INTRODUCTION

This section contains information on making connections to the Model 8007, as well as considerations when making measurements using the test fixture, and it is organized as follows:

**2.2 Fixture Configuration:** Details the test fixture connectors and sockets, and also discusses safety interlock connections.

**2.3 Matrix Card Connections:** Covers test fixture connections to the Model 7072 Semiconductor Matrix Card.

**2.4 Typical Instrument Connections:** Shows how to connect various types of instruments to the fixture, including source measure units, current and voltage sources, electrometers, and CV meters.

**2.5 Measurement Considerations:** Outlines a number of considerations that should be observed for optimum measurements made using the test fixture.

**2.6 Typical Applications:** Summarizes applications examples for the test fixture when used with appropriate test equipment.

**2.7 Using the Prototyping Board:** Summarizes use of the prototyping board for connection of custom circuits to the test fixture.

### 2.2 FIXTURE CONFIGURATION

#### 2.2.1 Rear Panel

The rear panel of the Model 8007 is shown in Figure 2-1. Key aspects of the rear panel include the six input/output mass-terminated connectors, the safety interlock connector, CHASSIS (MEASURE) and SUB CHASSIS

posts, the  terminal, and the plugged 3/8" holes for user expansion. Each of these items are discussed below.

 Screw

The  screw provides a connecting point for safety earth ground.

#### WARNING

To avoid electric shock, the  screw must be connected to safety earth ground using #18 AWG or large wire. Use the supplied safety grounding cable (Model 8007-GND-3).

#### Rear Panel Screws

#### WARNING

The two screws that secure the rear panel to the fixture base must be installed in order to ensure a good ground connection between the rear panel and the test fixture base.

#### Safety Interlock Connections

The safety interlock connector is intended for use with instruments equipped with a matching interlock connector to provide user safety when using hazardous voltages. Note that you must use the Keithley safety interlock cable (Model 236-ILC-3) with the instrument in order for the source measure unit to properly recognize whether the lid is open or closed.

Figure 2-2A shows typical connections to a Model 236 or 237 source measure unit. Note that the Model 8007 LID INTERLOCK connector is connected to one of the INTERLOCK connectors on the unit using the Model 236-ILC-3 interlock cable. With multiple source measure unit systems, all source measure units should be connected to the interlock by daisy chaining the interlock connectors of the source measure units together using additional Model 236-ILC-3 cables. Figure 2-2B shows an

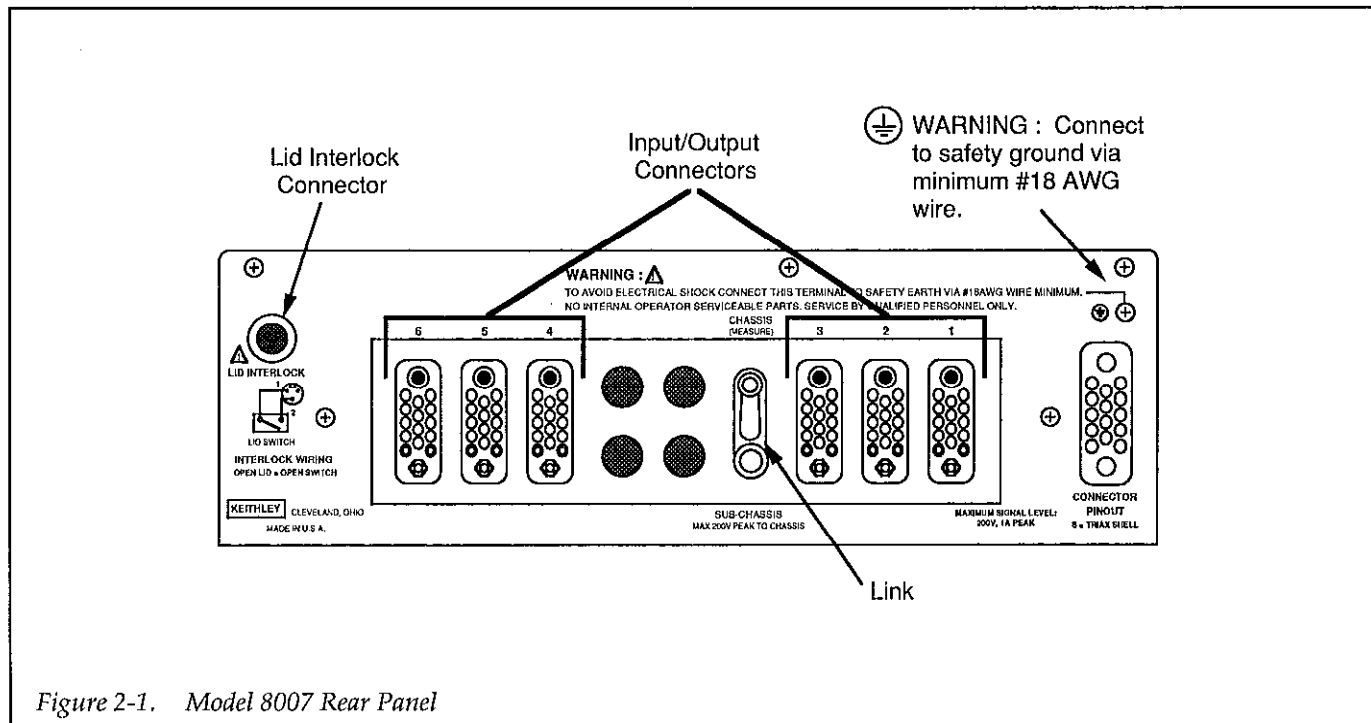

Figure 2-1. Model 8007 Rear Panel

example of a system using three source measure units all connected to one Model 8007 test fixture.

responds to the input/output numbering on the top panel, is summarized in Table 2-1.

For those using instruments without the standard interlock connector, the equivalent circuit of the internal interlock switch is shown in Figure 2-2C, both with lid open and lid closed.

**NOTE**  
The connector pinout is shown on the rear panel and in Figure 2-1.

**WARNING**  
User-supplied lethal voltages may be present when lid is open. Safe operation requires the use of the lid interlock.

The equivalent circuit for each input/output pathway is shown in Figure 2-3. Note that the inner shield of each triaxial cable is connected to the corresponding guard that surrounds the signal pathway. The outer cable shield is connected to chassis ground at either pin 13 or pin 14 of that particular connector.

**CAUTION**  
Do not exceed the voltage and current ratings of the safety interlock circuits (28V, 0.05A maximum).

**WARNING**  
Maximum signal level is 200V, 1A peak. Exceeding these values may create a shock hazard. See paragraph 2.5.13 for cumulative power restrictions.

### Input/Output Connectors

Input/output signal connections to the Model 8007 Test Fixture are made through the six mass-terminated connectors located on the rear panel. Each mating connector has 12 triax cables attached, for a total of 72 input/output connectors. The pathway numbering, which corre-

### Plugged 3/8" Holes

The four plugged 3/8" holes that are located on the rear panel can be used to install custom connectors such as the supplied 5-way binding posts. One possible use for these jacks would be to provide permanent power supply con-

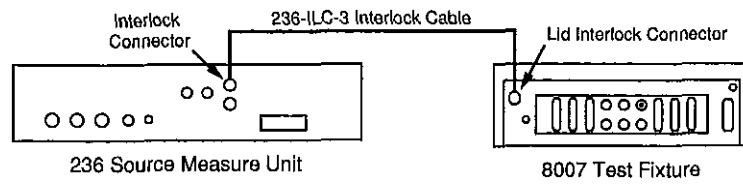

**A.) Connections to Single Source Measure Unit**

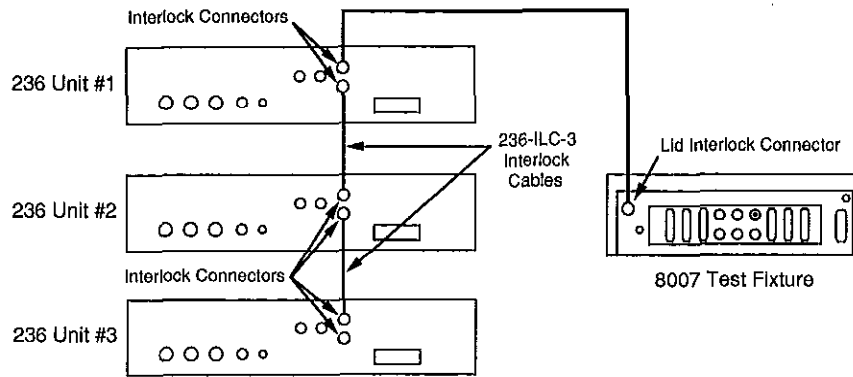

**B.) Multiple Source Measure Unit Interlock Connections**

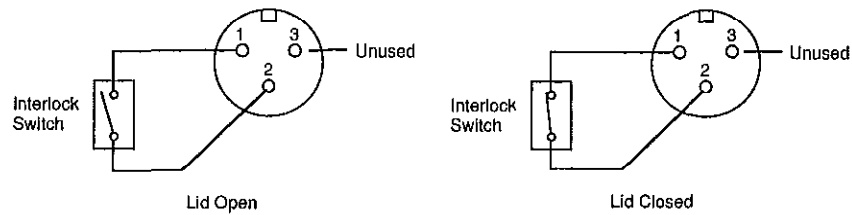

**C.) Equivalent Circuit**

Figure 2-2. Safety Interlock Connections

**Table 2-1. Input/output Numbering**

Connector Number	Connector Pin Number	Socket Pin Number*	Connector Number	Connector Pin Number	Socket Pin Number*
1	1	1	4	1	37
	2	2		2	38
	3	3		3	39
	4	4		4	40
	5	5		5	41
	6	6		6	42
	7	7		7	43
	8	8		8	44
	9	9		9	45
	10	10		10	46
	11	11		11	47
	12	12		12	48
2	1	13	5	1	1
	2	14		2	2
	3	15		3	3
	4	16		4	4
	5	17		5	5
	6	18		6	6
	7	19		7	7
	8	20		8	8
	9	21		9	9
	10	22		10	10
	11	23		11	11
	12	24		12	12
3	1	25	6	1	13
	2	26		2	14
	3	27		3	15
	4	28		4	16
	5	29		5	17
	6	30		6	18
	7	31		7	19
	8	32		8	20
	9	33		9	21
	10	34		10	22
	11	35		11	23
	12	36		12	24

\*Connectors 1-4 associated with 48-pin socket; connectors 5 and 6 pertain to 24-pin socket.

NOTE: Pins 13 and 14 of all six I/O connectors are connected to chassis ground and outer shields of triax cables.

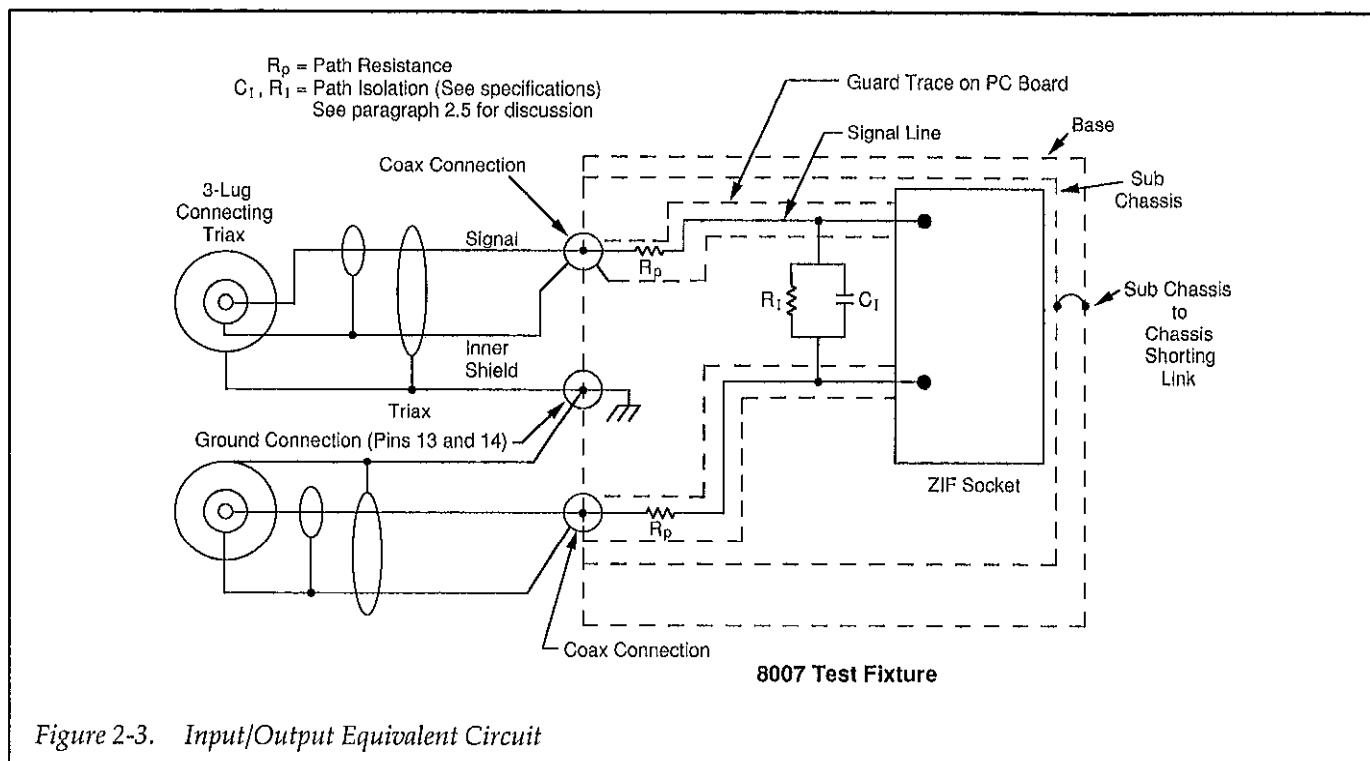

Figure 2-3. Input/Output Equivalent Circuit

nections to the two DIP sockets without having to route power through the triax cables. Refer to paragraph 3.7 for details on installing binding posts.

### SUB CHASSIS Post

The SUB CHASSIS post is intended for applying a guard signal from an external measuring or sourcing instrument. SUB CHASSIS is internally connected to the sub chassis that houses the circuit board.

#### WARNING

Do not exceed the 200V peak between SUB CHASSIS and CHASSIS. When using any binding post with hazardous voltages (>30V RMS), shut off all sources before connecting, and dress all leads so that no conductive surfaces are exposed.

#### NOTE

The shorting link that connects SUB CHASSIS to CHASSIS (MEASURE) should be disconnected from SUB CHASSIS when a guard signal is to be connected.

### CHASSIS (MEASURE) Post

The CHASSIS (MEASURE) binding post provides a convenient connecting point to fixture SUB CHASSIS. Normally, a shorting link is installed between this post and the SUB CHASSIS binding post, which places the sub chassis at chassis (earth) ground as well. If you intend to connect a guard signal or circuit LO, the shorting link must be removed from SUB CHASSIS.

#### WARNING

Do not use CHASSIS (MEASURE) for safety earth ground.

### 2.2.2 Front Panel

The front panel contains the 24-pin and 48-pin ZIF (zero insertion force) sockets for device connections (Figure 2-4). These two sockets can accommodate a variety of different DIP packages such as 14-, 16-, and 18-pin DIPs with 0.3 to 0.6-inch spacing. Also, the prototyping board, which is covered in paragraph 2.7, is designed to plug into these two sockets.

The sockets are individually numbered according to standard DIP convention (1-24 and 1-48). Table 2-1 sum-

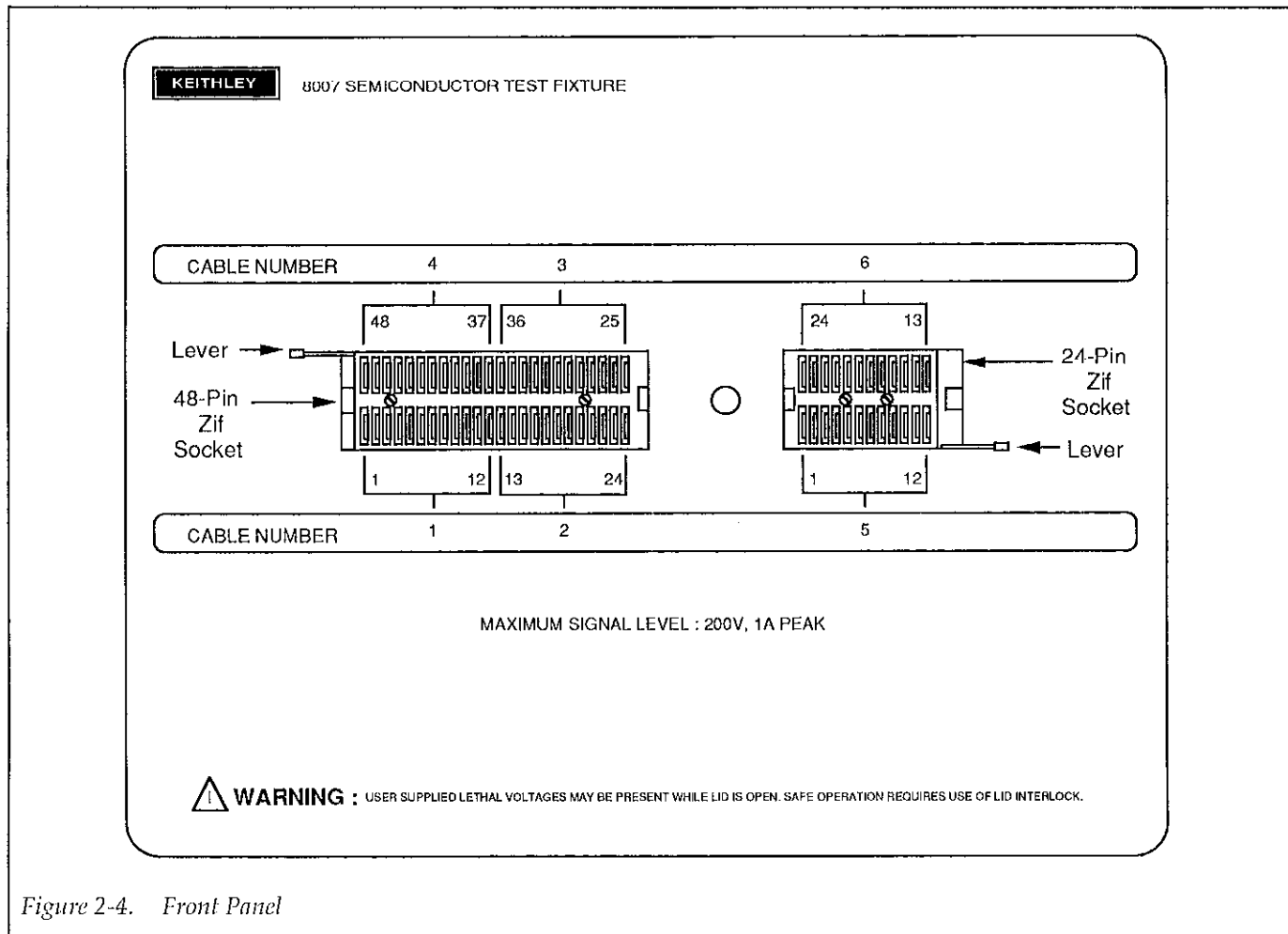

Figure 2-4. Front Panel

marizes I/O connections. The rear panel connector numbers are also shown on the front panel.

**WARNING**

User-supplied lethal voltages may be present while the lid is open. Safe operation requires the use of the safety interlock (paragraph 2.2.1).

To install a device in one of the sockets, simply lift the lever to open the socket holes, then carefully slide the pins of the device down into the socket. When the device is seated, move the socket lever down to the closed position to lock the device into place.

**NOTE**

With some devices you may encounter device oscillation resulting in incorrect readings. See

paragraph 2.5.10 for ways to verify the presence of oscillations and methods to minimize them.

**2.2.3 Sub Chassis Guarding**

The sub chassis on which the sockets are mounted is insulated from the fixture chassis and is separately shielded. In some cases, you may wish to drive the sub chassis at guard potential in order to minimize the effects of leakage resistance and capacitance. Guarding the sub chassis can be achieved by connecting the guard output of the measuring or sourcing instrument to the SUB CHASSIS jack on the rear panel. Figure 2-5 gives an example.

**NOTE**

Disconnect the shorting link connecting SUB CHASSIS to CHASSIS (MEASURE) before applying guard. To do so, loosen the binding



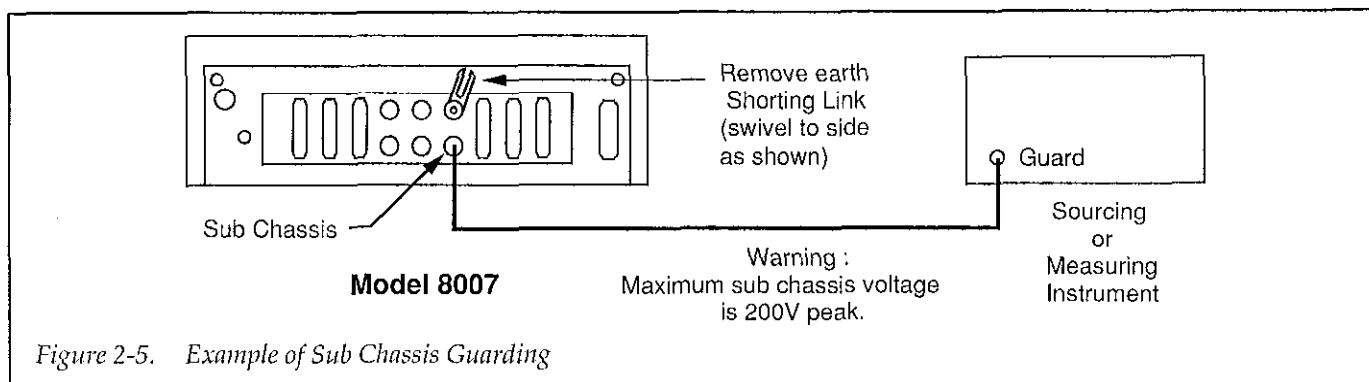

posts, then swivel the link aside and tighten the CHASSIS (MEASURE) binding post.

In order to be most effective, guard should be driven at the same dc potential as the most critical (lowest level) pathway to be guarded. If no guard is available, SUB CHASSIS can be connected to circuit LO for effective shielding of all pathways in the test fixture.

#### WARNING

Do not exceed the maximum recommended SUB CHASSIS voltage (200V peak).

#### NOTE

To avoid possible noise pickup, always connect SUB CHASSIS either to guard, LO, or CHASSIS (MEASURE).

## 2.3 MATRIX CARD CONNECTIONS

### Model 7072 Connections

The Model 8007 is intended primarily for use with the Model 7072 Semiconductor Matrix Card. The mass-terminated triax cable assemblies should be used to connect the test fixture to the matrix card. Figure 2-6(A) shows an example of how to connect the test fixture to one matrix card. Since each Model 8007 I/O connector has connections for 12 pathways, the most logical scheme would be to connect the test fixture to the columns on the Model 7072.

For additional switching pathways, additional matrix cards must be used. Six Model 7072 cards installed in one

mainframe will result in the same 72-pin test capability as the Model 8007 test fixture.

When making connections, keep in mind that all rows on the Model 7072 are not the same. Rows A and B are low-current rows, rows C through F are general-purpose rows, and rows G and H are CV rows. See the Model 7072 Instruction Manual for complete details.

### Model 7152 Low-Current Matrix Card

Typical connections to a Keithley Model 7152 Low-Current Matrix Card are shown in Figure 2-6(B). Each cable on the Model 8007-MTC-3 cable is connected to a cable on the Model 7152-T cable using Pomona Model 5278 female-to-female triax adapters.

### Model 7073 Coaxial Matrix Card

Figure 2-6(C) shows typical connections to a Model 7073 Coaxial Matrix Card. Note that each cable on the Model 8007-MTC-3 cable is connected to a BNC jack on the matrix card using Pomona Model 5299 3-lug triax to BNC adapters.

## 2.4 TYPICAL INSTRUMENT CONNECTIONS

The following paragraphs show how to connect the Model 8007 to various types of instruments through a Model 7072 Semiconductor Matrix Card. For detailed information on cabling for matrix card-to-instrument connections, refer to the Model 7072 Instruction Manual, as well as the test instrument's instruction manual.

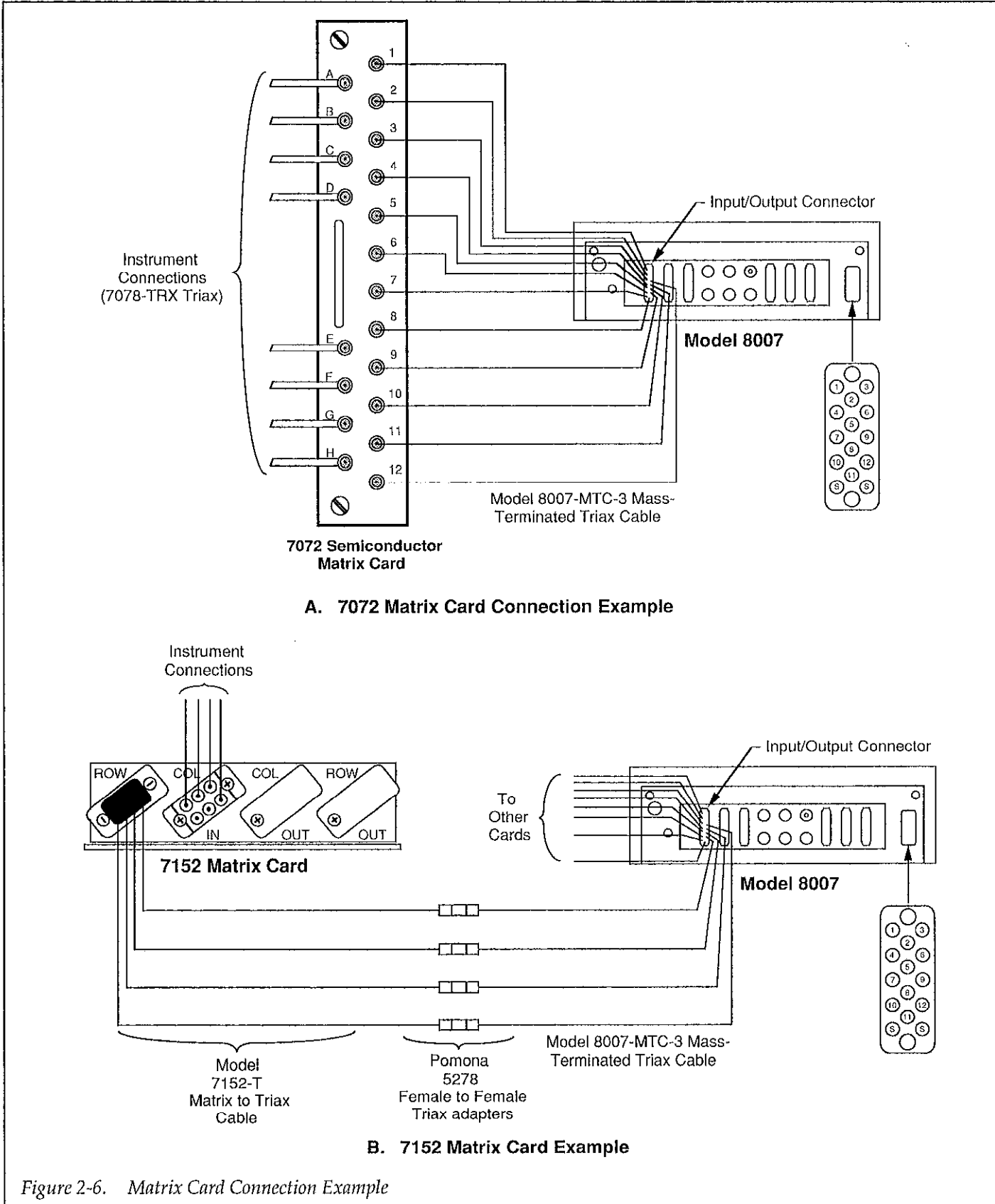
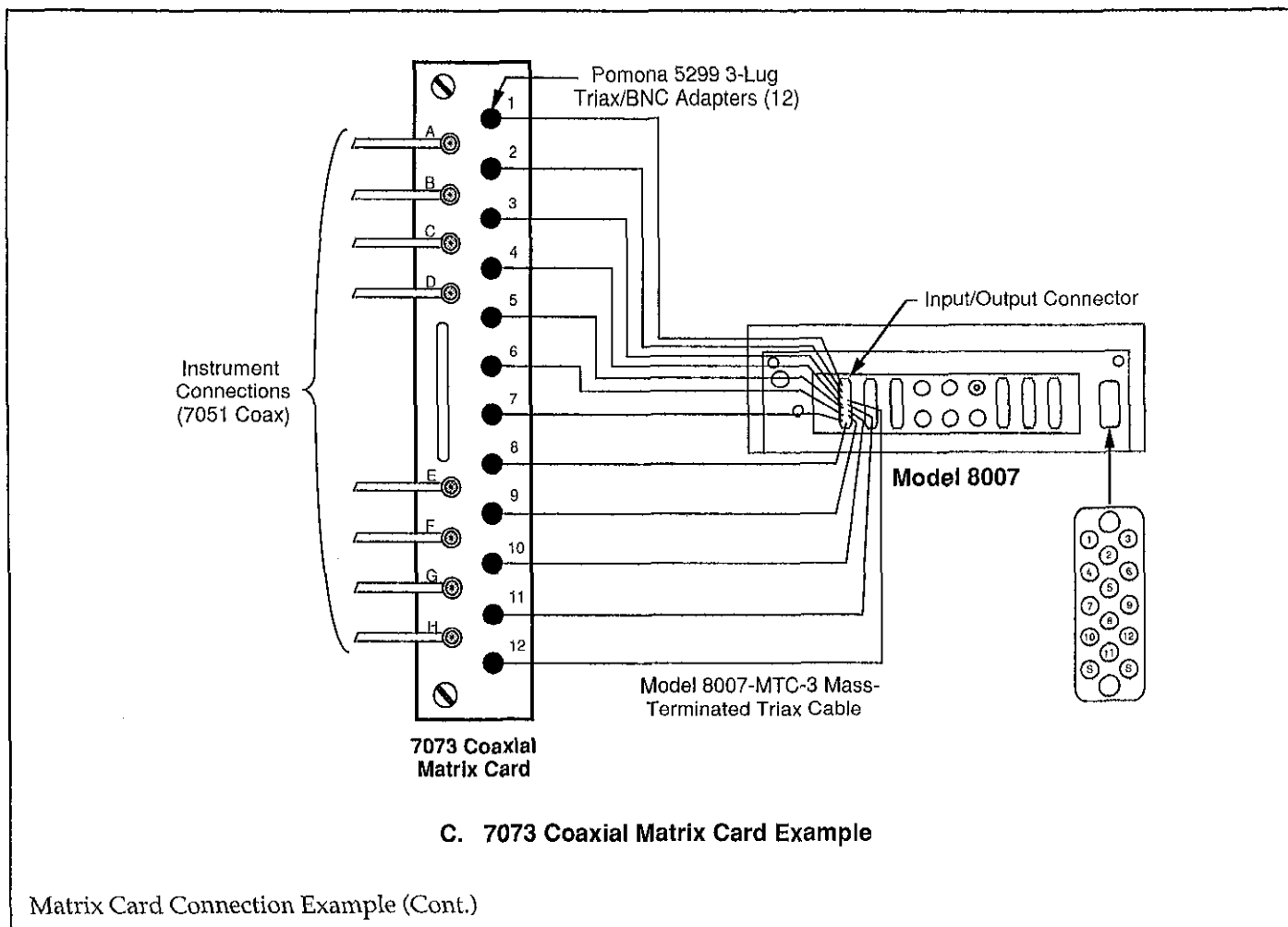

Figure 2-6. Matrix Card Connection Example



### 2.4.1 Adapters

In some cases, special adapters will be necessary to connect the Model 8007-MTC-3 triax cables to the instruments. Figure 2-7 shows typical connecting schemes for

triax to banana, triax cable to triax cable, 3-slot triax to 2-lug triax, and triax to BNC connectors.

**NOTE**

For some connections, no commercial adapters are available. In those cases, it will be necessary to construct custom cables.

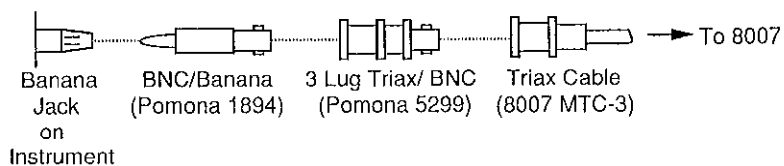

A.) Triax/Banana

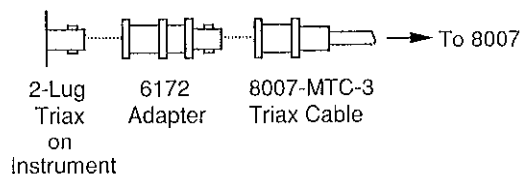

B.) 3-Lug Triax to 2-Lug Triax

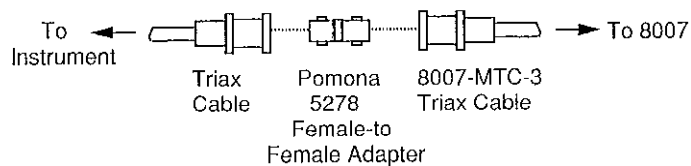

C.) Triax Cable to Triax Cable

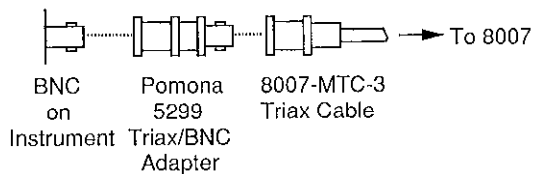

D.) Triax to BNC

Figure 2-7. Adapters Required for Connections

## 2.4.2 Source Measure Unit

Typical connections for a source measure unit are shown in Figure 2-8. Note that the unit is connected to the rows, while the test fixture itself is connected to the columns. The mass-terminated triaxial cables are used to make the connections between the test fixture and the matrix card, while conventional triax cables should be used for connections between the unit and the matrix card.

### NOTE

With some devices you may encounter device oscillation resulting in incorrect readings. See paragraph 2.5.10 for ways to verify the presence of oscillations and methods to minimize them.

### Remote Sensing

The connections shown in Figure 2-8A are intended for use with the source measure unit in remote sensing mode. Remote sensing should be used when voltage drops across the test leads and connectors are a consideration. When using remote sensing, it will be necessary to connect two pathways to each side of the DUT. Either cut and jumper the circuit board, wire-up the prototyping board for Kelvin connections (as covered in para-

graph 2.7), or install short jumper wires between socket terminals.

### Local Sensing

The connections shown in Figure 2-8B should be used with the source measure unit in the local sensing mode. Note that only two pathways are necessary through the matrix card and test fixture to the DUT; no test fixture modifications are necessary to use local sensing.

## 2.4.3 DMM (Digital Multimeter)

Typical connections for a DMM (for example, a Model 199) are shown in Figure 2-9. Two-wire connections are shown in Figure 2-9(A), and 4-wire connections are shown in Figure 2-9(B).

### NOTE

As with source measure unit connections, the 4-wire connections will require adjacent socket terminal jumpering or special prototyping board wiring (paragraph 2.7) so that two pathways are connected to each side of the DUT.

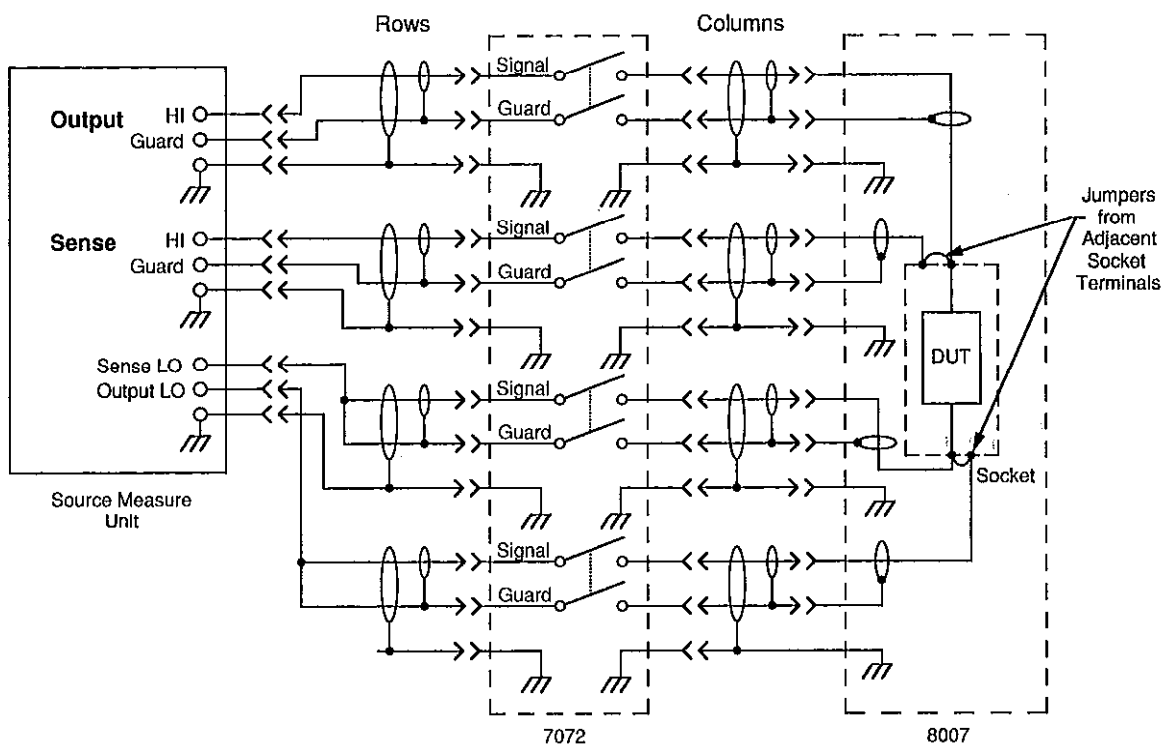

A. Remote Sensing  
(Kelvin connections)

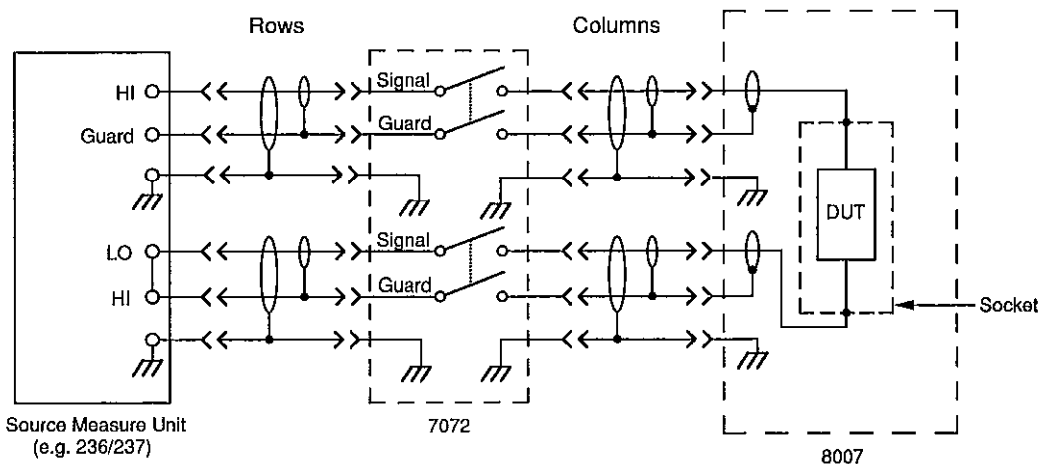

B. Local Sensing

Figure 2-8. Source Measure Unit Connections

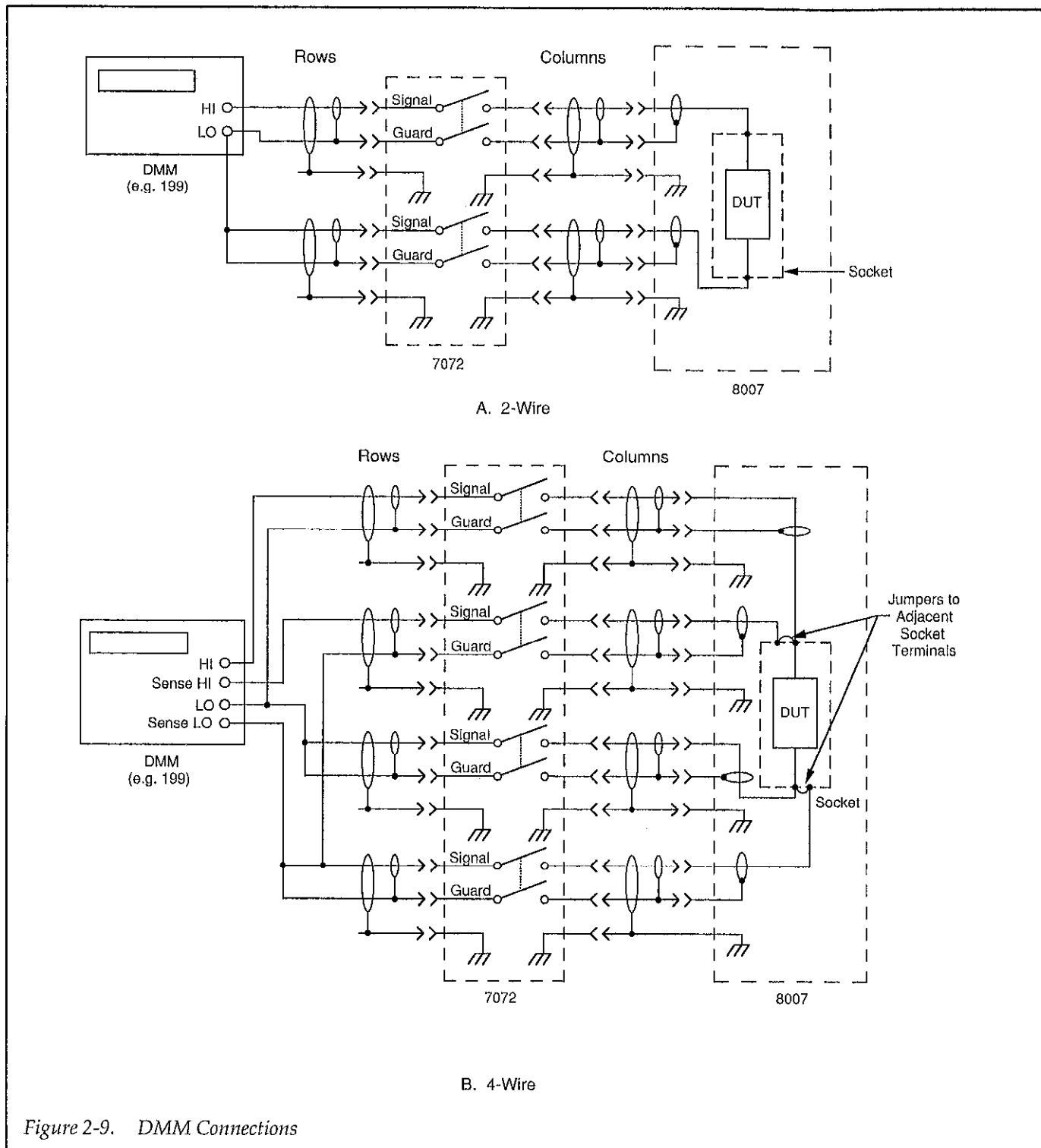

Figure 2-9. DMM Connections

### 2.4.4 Electrometer

Two examples of electrometer connections are shown in Figure 2-10. Guarded and unguarded volts connections are shown in Figure 2-10(A) and Figure 2-10(B), fast current connections are shown in Figure 2-10(C), and guarded resistance connections are shown in Figure 2-10(D).

### 2.4.5 Source Connections

Typical voltage and current source connections are shown in Figure 2-11 and Figure 2-12 respectively. Voltage source connections are typically unguarded, while current source connections are shown guarded, which is the preferred configuration for low-level currents.

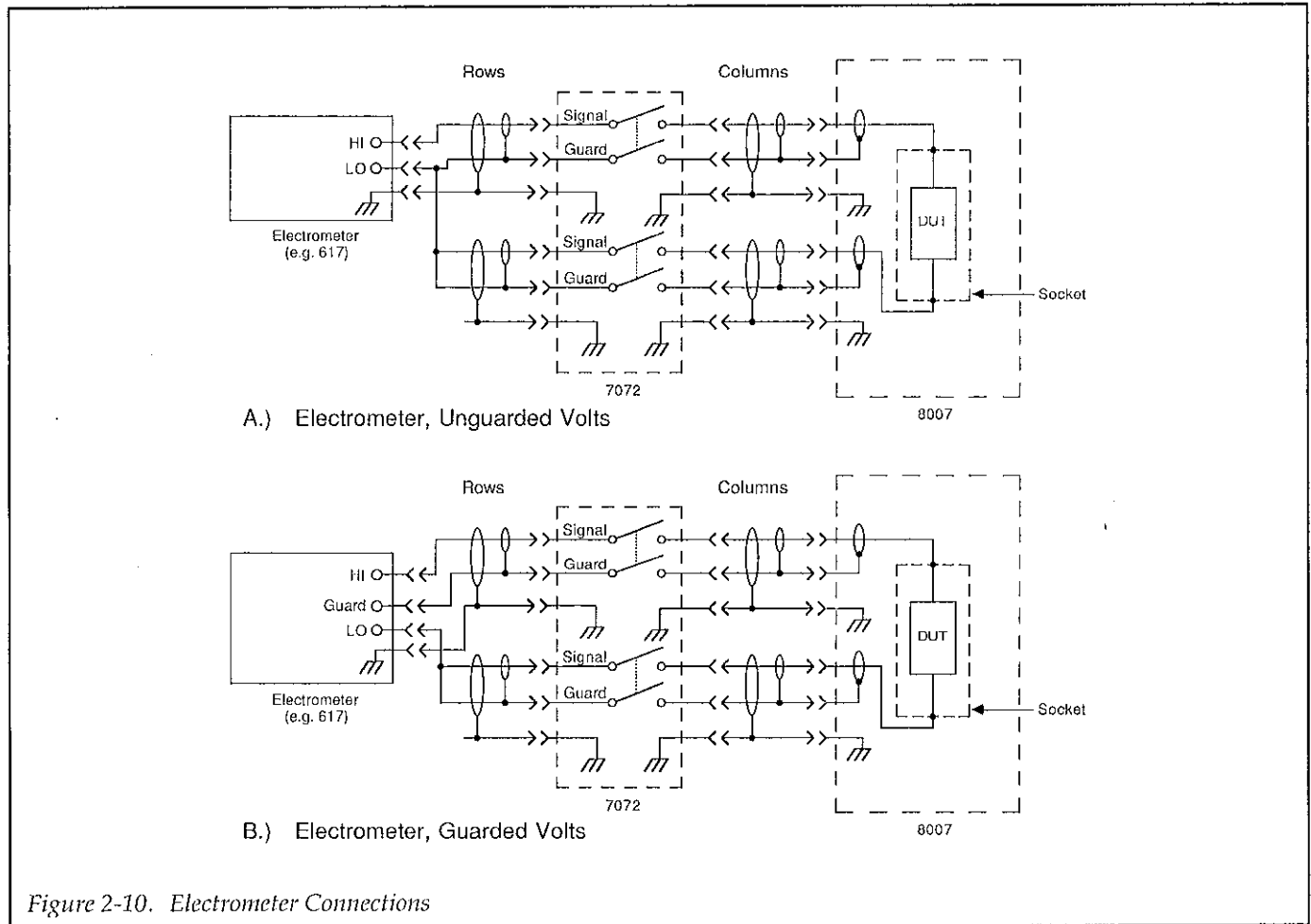



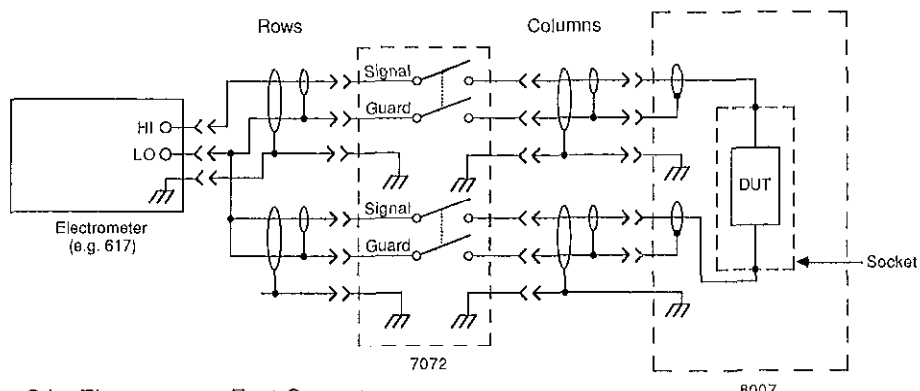

C.) Electrometer, Fast Current

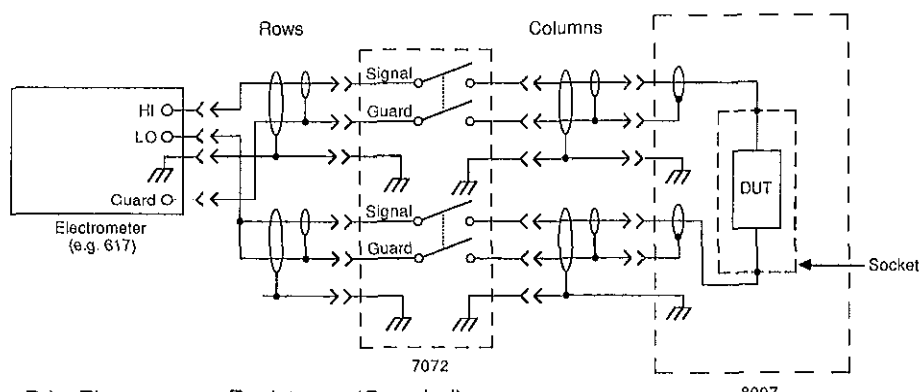

D.) Electrometer, Resistance (Guarded)

Electrometer Connections (Cont.)

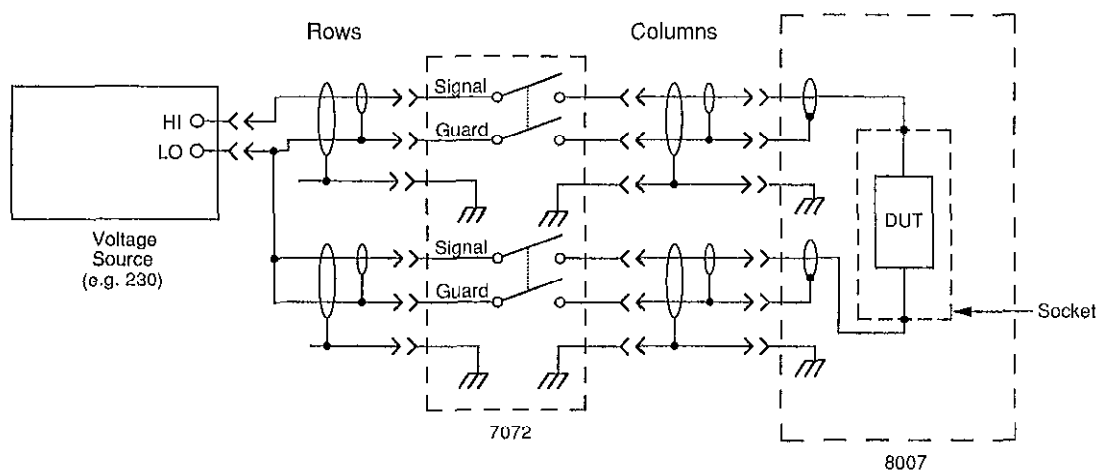
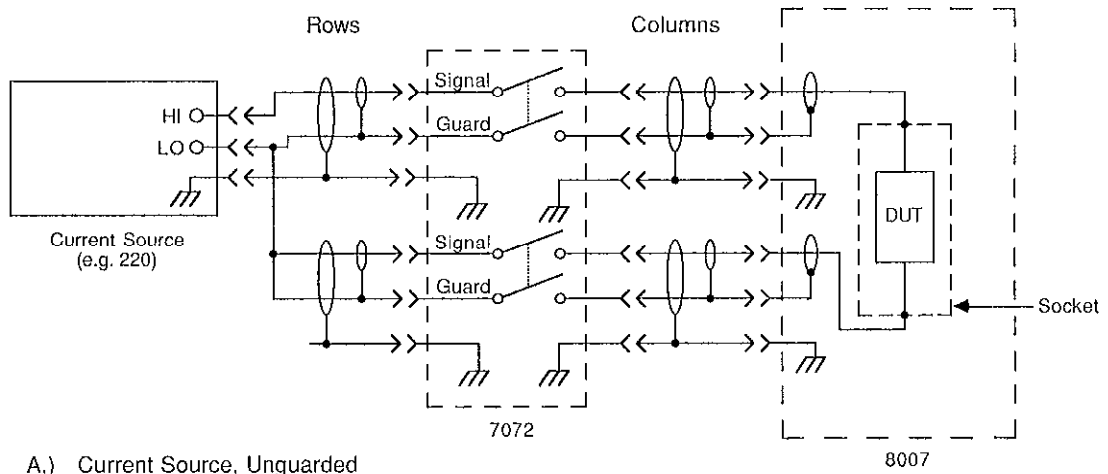
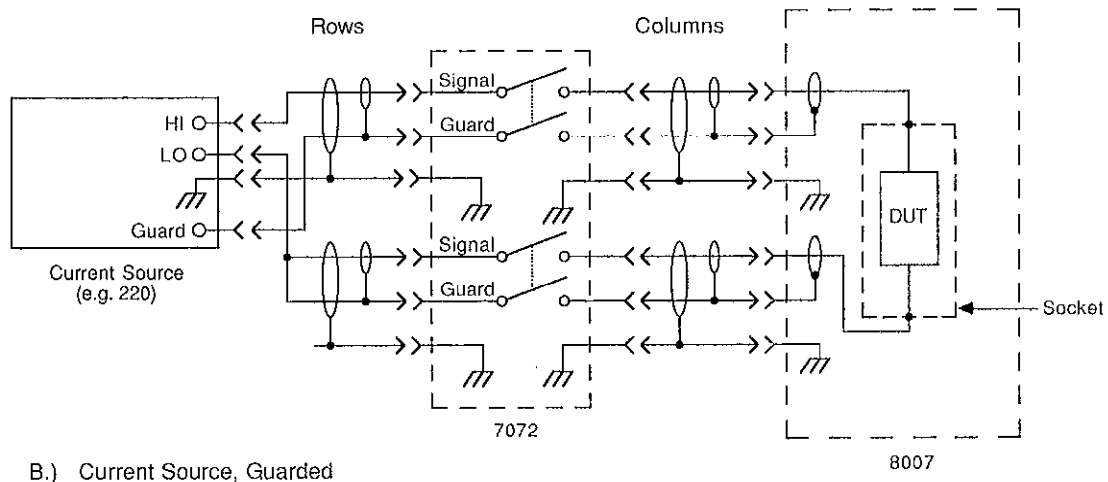

Figure 2-11. Voltage Source Connections



A.) Current Source, Unguarded



B.) Current Source, Guarded

Figure 2-12. Current Source Connections

## 2.5 MEASUREMENT CONSIDERATIONS

Many measurements made with the Model 8007 can be affected by noise and leakage paths. The following paragraphs discuss possible problems that might affect these measurements and ways to minimize their effects.

### 2.5.1 Path Isolation

The path isolation is simply the equivalent impedance between any two test paths in a measurement system. Ideally, the path isolation should be infinite, but the actual resistance and distributed capacitance of cables, connectors, and sockets results in less than infinite path isolation values for these devices.

Path isolation resistance forms a signal path that is in parallel with the equivalent resistance of the DUT, as shown in Figure 2-13. For low-to-medium device resistance values, path isolation resistance is seldom a consideration; however, it can seriously degrade measurement accuracy when testing high-impedance devices. The voltage

measured across such a device, for example, can be substantially attenuated by the voltage divider action of the device source resistance and path isolation resistance, as shown in Figure 2-14. Also, leakage currents can be generated through these resistances by voltage sources in the system.

Any distributed capacitance between measurement pathways affects dc measurement settling time as well as ac measurement accuracy. Thus, it is important that such capacitance be kept as low as possible. Although the distributed capacitance of the test fixture and switching matrix card is generally fixed by design, there is one area where you do have control over the capacitance in your test system: the connecting cables. Use only low-capacitance cabling, and keep all cables as short as possible.

The effects of path resistance and capacitance can be minimized by using guarding whenever possible. Paragraph 2.5.4 discusses guarding in more detail.

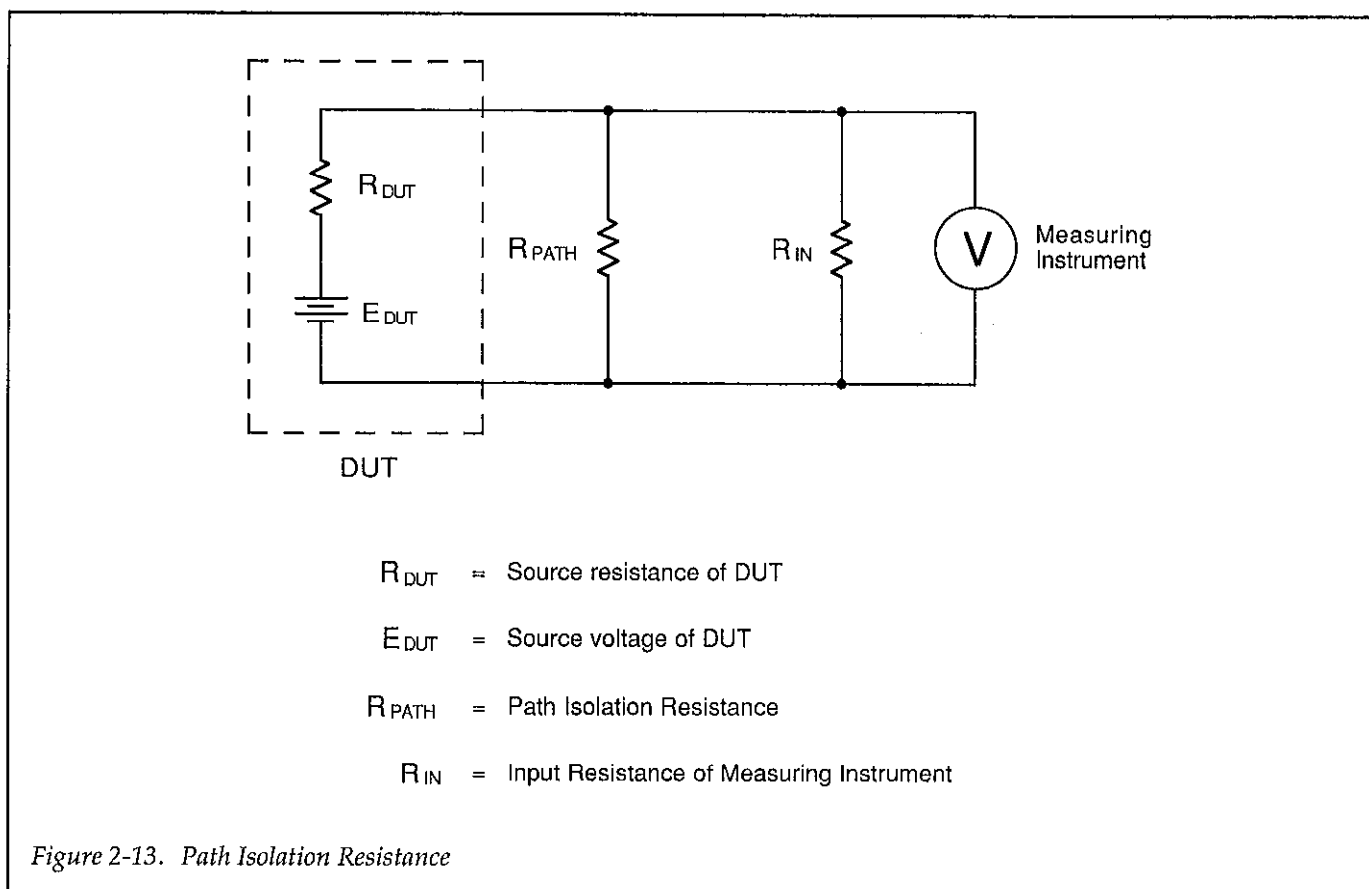

Figure 2-13. Path Isolation Resistance

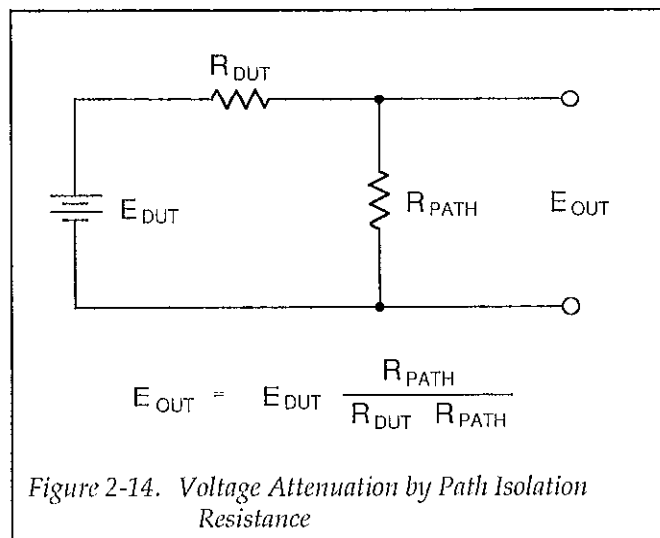

Figure 2-14. Voltage Attenuation by Path Isolation Resistance

### 2.5.2 Keeping Connectors and Sockets Clean

As is the case with any high-resistance device, the integrity of connectors and sockets can be compromised if they are not handled properly. If the insulation becomes contaminated, the path isolation resistance will be substantially reduced, affecting high-impedance measurements.

Oils and salts from the skin can contaminate insulators, reducing their resistance. Also, contaminants present in the air can be deposited on the insulator surfaces. To avoid these problems, never touch the connector or socket insulating material. In addition, the test fixture should be used only in clean, dry environments to avoid contamination.

If the connector or socket insulators should become contaminated, either by inadvertent touching, or from airborne deposits, they can be cleaned with a cotton swab dipped in clean methanol. After thorough cleaning, they should be allowed to dry for several hours in a 50°C low-humidity environment before use, or they can be dried more quickly using dry nitrogen gas. Do not use air from an ordinary air compressor because oil present in the air may result in contamination.

### 2.5.3 Shielding

Proper shielding of all signal paths and devices under test is important to minimize noise pickup in virtually

any semiconductor test system. Otherwise, interference from such noise sources as line frequency and RF fields can seriously corrupt a measurement.

For unguarded measurements, the inner shield of the triaxial cable that surrounds the signal path should be connected to signal LO (or chassis ground for instruments without isolated LO terminals). An example of how to maintain a shielded pathway from an instrument, through the matrix card, to the test fixture is shown in Figure 2-15.

### 2.5.4 Guarding

Guarding is important in high-impedance circuits where leakage resistance and capacitance could have degrading effects on the measurement. Guarding consists of using a shield surrounding a conductor that is carrying the high-impedance signal. This shield is driven by a low-impedance amplifier to maintain the shield at signal potential. For triaxial cables, the inner shield is used as guard. With the Model 8007 test fixture, each guard pathway is carried through as close as possible to the corresponding device socket pin.

Guarding minimizes leakage resistance effects by driving the inner cable shield with a unity-gain amplifier, as shown in Figure 2-16. Since the amplifier has a high input impedance, it minimizes loading on the high-impedance signal lead. Also, the low output impedance ensures that the shield remains at signal potential, so that virtually no leakage current flows through the leakage resistance,  $R_L$ . Leakage between inner and outer shields may be considerable, but that leakage is of little consequence because that current is supplied by the buffer amplifier rather than the signal itself.

In a similar manner, guarding also reduces the effective cable capacitance, resulting in much faster measurements on high-impedance circuits. Because any distributed capacitance is charged through the low impedance of the buffer amplifier rather than by the source, settling times are shortened considerably by guarding.

In order to use individual pathway guarding effectively with the Model 8007, the inner shield of the connecting triaxial cable carrying the HI signal path should be connected to the guard output of the sourcing or measuring instrument. That guard output should be at the same dc potential as the signal being guarded. For the LO signal path, simply connect the inner shield to LO at the measuring or sourcing instrument.

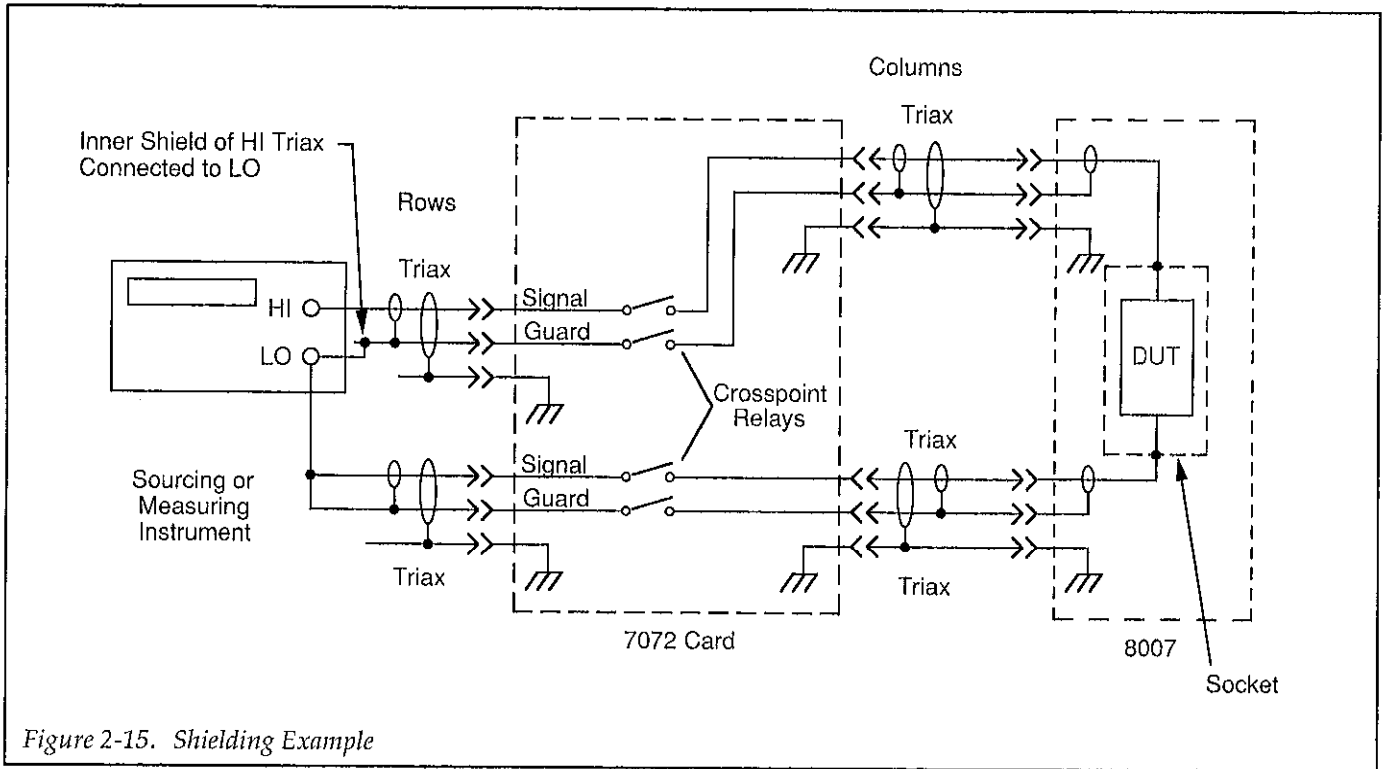

Figure 2-15. Shielding Example

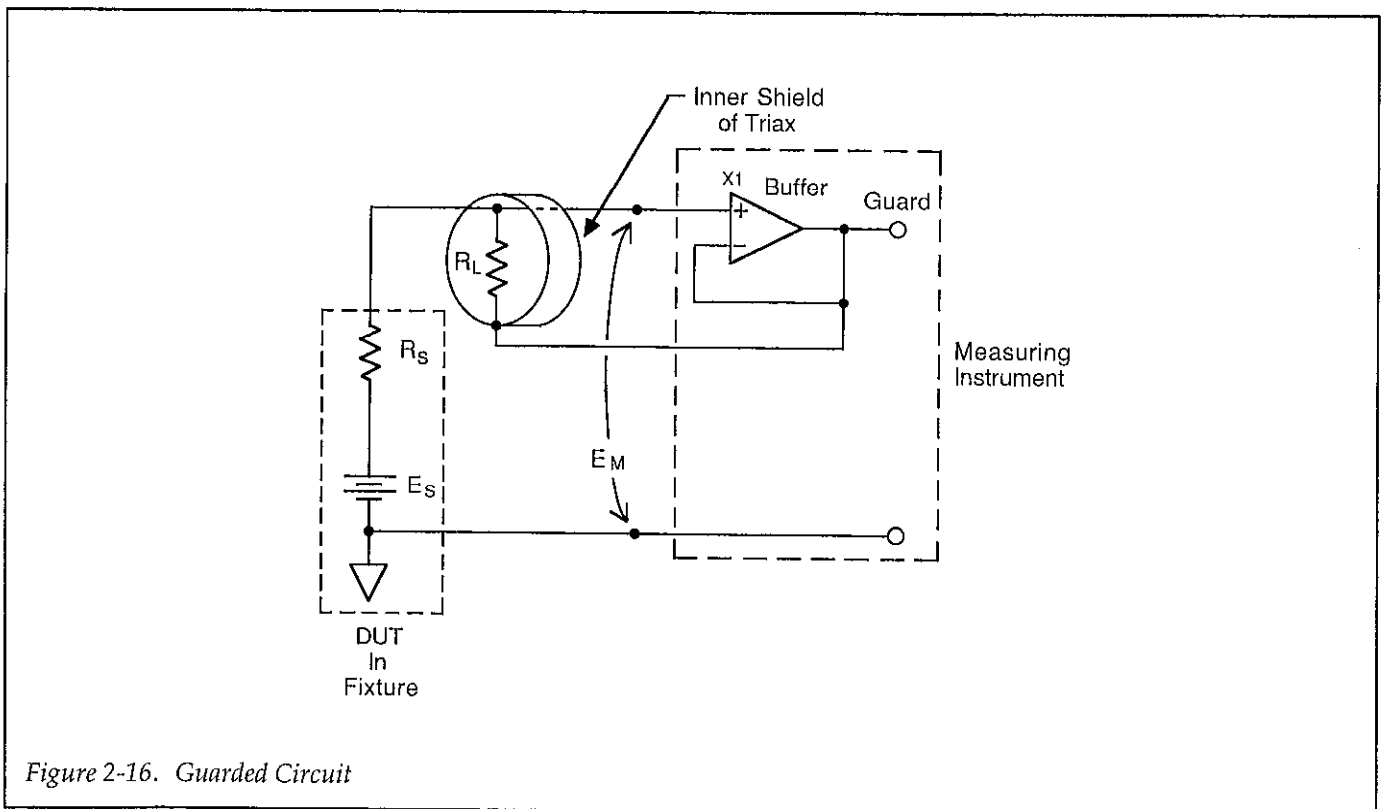

Figure 2-16. Guarded Circuit

Figure 2-17 shows typical guarded connections, with the guard path carried through the matrix card. Guard is carried through internally to the corresponding test socket pin in order to provide maximum guarding benefits.

The entire sub chassis can also be guarded by connecting a suitable guard potential to the rear panel SUB CHASSIS jack of the test fixture. If no guard is available, connect the SUB CHASSIS jack to circuit LO at a convenient point in order to effectively shield internal fixture pathways.

**WARNING**  
Maximum voltage between SUB CHASSIS and CHASSIS (MEASURE) is 200V peak.

### 2.5.5 Cable Noise Currents

Noise currents can be generated by bending or flexing the triaxial connecting cables. These currents, which are known as triboelectric currents, are generated by charges created between a conductor and insulator caused by

friction. Piezoelectric charges are also generated by applying pressure to the cable.

In order to minimize cable noise currents, tie down cables to avoid flexing, and isolate the cables from vibration sources such as motors and pumps. Also, avoid temperature extremes that could lead to cable expansion and contraction.

### 2.5.6 Magnetic Fields

When a conductor loop cuts through magnetic lines of force, a very small current is generated. This phenomenon will frequently cause unwanted signals to occur in the test leads of a test system. If the conductor has sufficient length, even weak magnetic fields like those of the earth can create sufficient signals to affect low-level measurements.

Two ways to reduce these effects are: (1) reduce the lengths of the connecting cables, and (2) minimize the exposed circuit area. In extreme cases, magnetic shielding may be required. Special metal with high permeability at low flux densities (such as mu metal) are effective at reducing these effects.

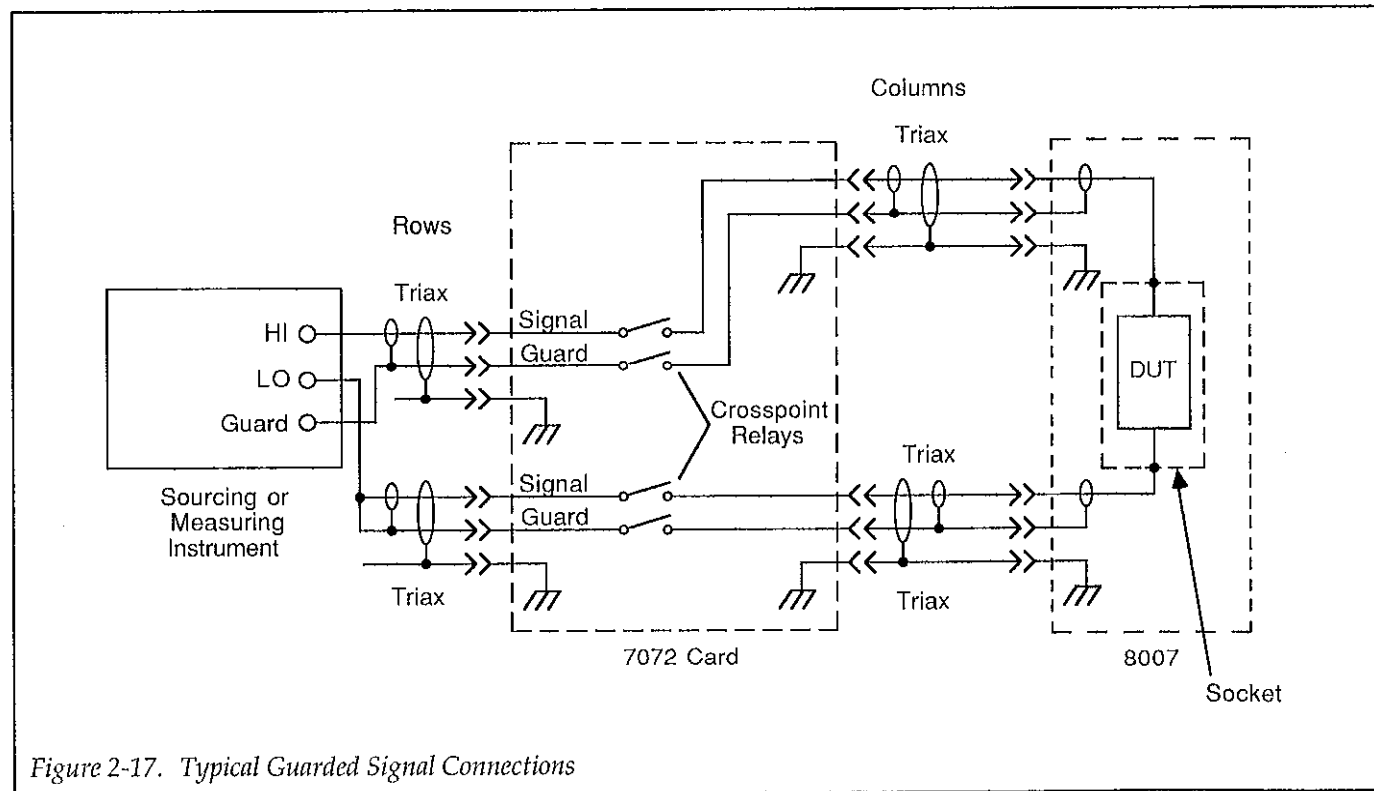

Figure 2-17. Typical Guarded Signal Connections

Even when the conductor is stationary, magnetically-induced signals may still be a problem. Fields can be produced by various signals such as the ac power line voltage. Large inductors such as power transformers can generate substantial magnetic fields, so care must be taken to keep the test fixture a good distance away from these potential noise sources.

### 2.5.7 Radio Frequency Interference

RFI (Radio Frequency Interference) is a general term used to describe electromagnetic interference over a wide range of frequencies across the spectrum. Such RFI can be particularly troublesome at low signal levels, but it can also affect measurements at high levels if the problem is of sufficient severity.

RFI can be caused by steady-state sources such as radio or TV signals, or some types of electronic equipment (microprocessors, high speed digital circuits, etc.), or it can result from impulse sources, as in the case of arcing in high-voltage environments. In either case, the effect on the measurement can be considerable if enough of the unwanted signal is present.

RFI can be minimized in several ways. The most obvious method is to keep the test fixture and signal leads as far away from the RFI source as possible. Additional shielding of the test fixture, signal leads, sources, and measuring instruments will often reduce RFI to an acceptable level. In extreme cases, a specially-constructed screen room may be required to sufficiently attenuate the troublesome signal.

Many instruments incorporate internal filtering that may help to reduce RFI effects in some situations. In some cases, additional external filtering may also be required. Keep in mind, however, that filtering may have detrimental effects on the desired signal.

### 2.5.8 Ground Loops

When two or more instruments are connected together, care must be taken to avoid unwanted signals caused by ground loops. Ground loops usually occur when sensitive instrumentation is connected to other instrumentation with more than one signal return path such as power line ground. As shown in Figure 2-18, the resulting ground loop causes current to flow through the instru-

ment LO signal leads and then back through power line ground. This circulating current develops a small but undesirable voltage between the LO terminals of the two instruments. This voltage will be added to the source voltage, affecting the accuracy of the measurement.

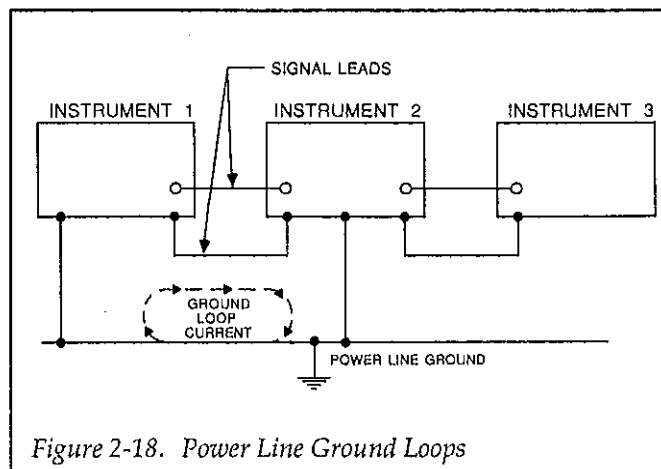

Figure 2-18. Power Line Ground Loops

Figure 2-19 shows how to connect several instruments together to eliminate this type of ground loop problem. Here, only one instrument is connected to power line ground.

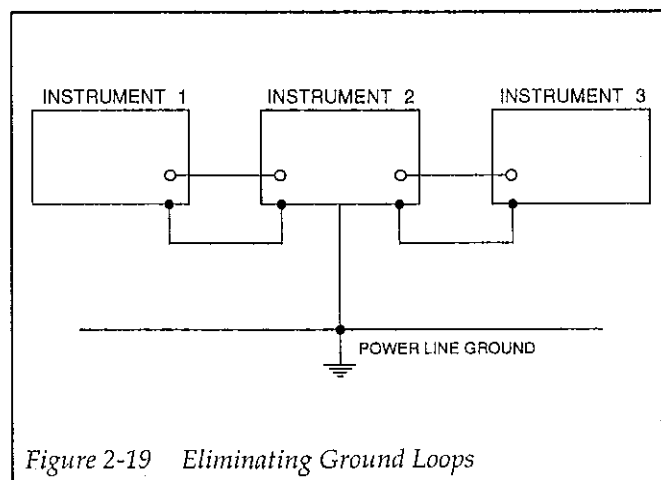

Figure 2-19 Eliminating Ground Loops

Ground loops are not normally a problem with instruments having isolated LO terminals. However, all instruments in the test setup may not be designed in this manner. When in doubt, consult the manual for all instrumentation in the test setup.

### 2.5.9 Capacitance Considerations

When making critical low-capacitance measurements, keep in mind that the worst (highest) capacitance performance of the test fixture is between adjacent socket pins. To minimize the effects of socket capacitance, measure between non-adjacent socket terminals. For example, assume you wish to measure the value of a discrete capacitor by connecting the device between socket pins. In this case, it would be better to connect the capacitor across the socket rather than between adjacent socket pins.

### 2.5.10 Device Oscillation

In some cases, you may encounter device oscillation that will affect your measurements. Such oscillations are not caused by the test fixture, but they can be present if sufficient positive feedback is present in the test system. This feedback can be caused by such factors as the additional capacitance of the test cables.

If present at all, oscillations will be seen more often with multiple-instrument setups (for example, with source measure units) when testing devices with high gain-bandwidth products such as RF FETs, or with negative-resistance devices such as UJT's.

#### Verifying the Presence of Oscillations

With dc testing, the most obvious signs of possible oscillations are:

- Unrepeatable or unstable measurements
- Inconsistent readings across ranges
- Unexpected data values
- Data changing significantly with the integration rate of the instrument
- Changes in data with added instrument filtering.

If any of these symptoms are noted, the presence of oscillations can be verified with an oscilloscope. Note, however, that connecting an oscilloscope may affect the oscillation, either increasing or decreasing them, or possibly even dampening them completely.

#### Using Ferrite Beads

Using the supplied ferrite beads may solve the oscillation problem. These ferrite beads can be permanently installed in all pathways going to the device under test.

The ac response of the pathways with ferrite beads will be reduced, although the bulk dc resistance is very low. Note that the beads must be installed as close to the device package as possible to be most effective. Since these beads typically have an inductance in the  $\mu\text{H}$  range or less, this solution may be useful only for higher oscillation frequencies (above 10MHz or so).

#### Supplied Ferrite Beads

As summarized in Table 2-2, a total of 24 each of three types of ferrite beads are supplied with the Model 8007. These beads include leadless versions of Fair-Rite Products Corp. types #43 and #73 ferrite material. A version of type #43 with leads is also supplied for ease of construction.

Table 2-2. Supplied Ferrite Beads

Qty.	Description	Keithley Part Number
24	Type #73, leadless	CH-48
24	Type #43, leadless	CH-49
24	Type #43, with leads	CH-50

#### Installing Ferrite Beads

If oscillation is found to be a problem, install ferrite beads in the appropriate pathways on the prototyping board supplied with the Model 8007 (see paragraphs 2.5.10 and 2.7 of instruction manual for information on device oscillation and details on using the prototyping board). In most cases, best results will be obtained by installing beads on the gate or base leads of the DUTs. Since the effective bead impedances at the frequency of interest are typically less than  $100\Omega$  (see below), it may be necessary to use two or more beads, particularly in difficult cases.

#### Suppression Capabilities

Figure 2-20 shows how the impedance of the type #73 beads varies with frequency. Note that this material is optimized for use below 40MHz. Figures 2-21 and 2-22 show the impedance vs. frequency curve of the type #43 material with and without leads, which is optimized for use above 40MHz, up to a maximum of 200MHz. Note that installation of ferrite beads may have undesirable effects on the AC frequency characteristics of the test circuit.



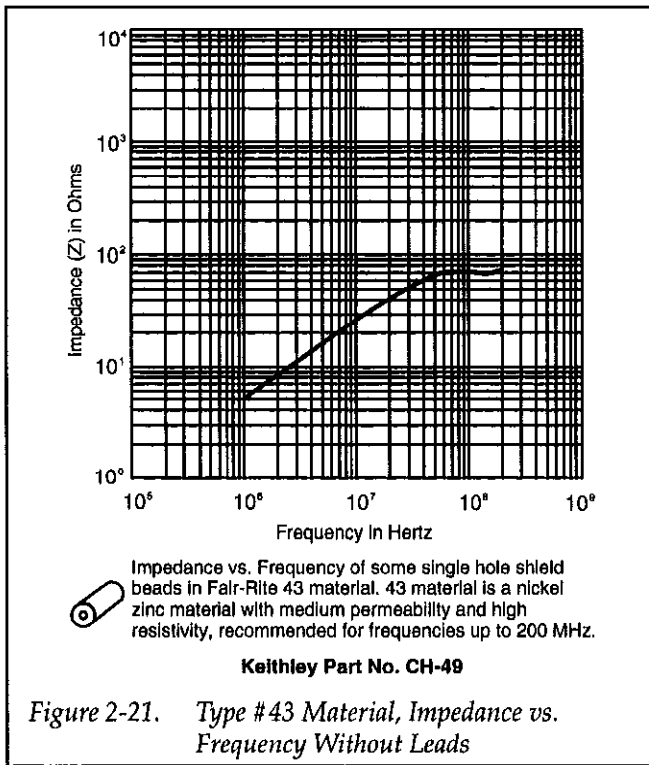
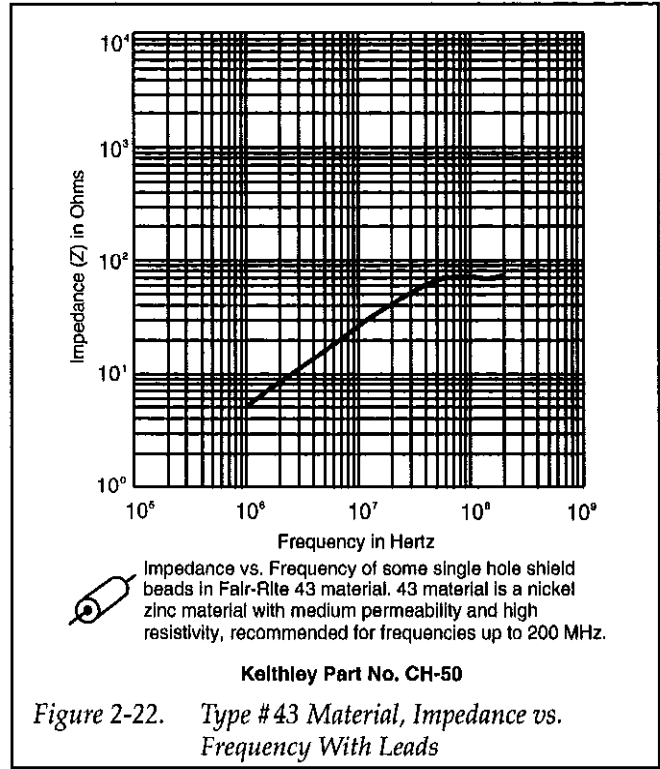
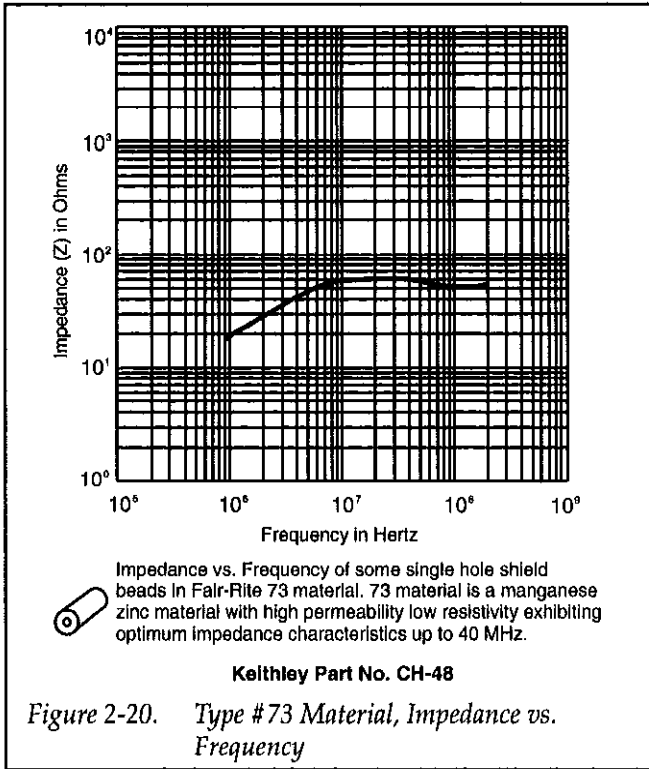

### Using Resistors

Another solution for oscillation — one that may also be useful at lower frequencies — is to install series resistors in the source or emitter of the DUT in order to reduce overall gain. Some experimentation will be necessary to determine the optimum value. In many cases, a small resistance value will be all that is necessary to dampen oscillations. In more serious cases, higher values will be required. If you do install a series resistor, keep in mind that it may have detrimental effects on other aspects of the measurements. Always select as small a resistance value as possible to minimize these effects.

### LC Filters

For extreme cases, small LCT filters are available. These filters can be mounted directly on the circuit board with the inductive elements in series with the pathway, while the capacitance element should be placed in parallel with the pathway. Again, installing filters will affect the ac performance of the test fixture.

## Installing Components

In order to install series components, it will be necessary to cut the individual circuit board traces going to the socket terminals. For maximum benefit, devices should be installed by soldering them to the traces as close to the socket terminals as possible. Paragraph 3.6 discusses circuit board modification in more detail. Before modifying the test fixture, you may wish to verify that the proposed remedy is viable by constructing a test circuit on the prototyping board (paragraph 2.7).

### CAUTION

**Installing components or otherwise modifying the test fixture may degrade fixture performance specifications.**

## 2.5.11 Environmental Considerations

### Cleanliness

The test fixture should be operated only in a clean environment. Otherwise, any dust or dirt that settles on the fixture sockets or connectors could degrade fixture specifications. Even if front panel sockets are periodically cleaned, long-term internal dirt build-up could also affect specifications. If such contamination is suspected, perform the performance verification procedures outlined in Section 3. Clean all internal parts using the procedure discussed in paragraph 3.3 if contamination is verified.

### Humidity

The test fixture should be operated within the humidity limits given in the specifications at the front of this manual. Note that current and path isolation in particular are affected by humidity. For best results, use the fixture in a low-humidity environment.

### Light

Some devices are affected by light, which is the main reason the Model 8007 is equipped with a light-tight gasket. In order to ensure that the light-tight environment for the device is maintained, periodically check the gasket in the base for deterioration. Also, make certain that no obstructions such as test leads keep the lid from seating properly.

## 2.5.12 Vibration

Any vibration could affect fixture performance due to piezoelectric and triboelectric effects. To obviate these effects, keep the fixture and cables as far away as possible from vibration-producing sources such as

motors and pumps. Place the test fixture on a vibration-isolating base such as rubber if vibration sources cannot be completely eliminated.

## 2.5.13 Low Current and Low Voltage Measurements

The effects of the fixture offset current come into play with very low currents. To minimize these effects, enable the instrument zero or suppression feature with no device installed in the sockets and the lid closed to cancel the offset current. Install the device, and make the measurement with zero or suppress enabled. Measurements should be made as soon as possible after suppression to ensure that the offset currents are properly suppressed.

Similarly, low-voltage measurements can be affected by thermal EMF voltages. These voltages, which are typically generated at connector and relay contact points, can also be suppressed by using the zero feature of the measuring instrument. However, since these offsets are thermally generated, temperature variations will cause their values to drift. For that reason, the fixture should be operated in a thermally-stable environment, especially when making critical, low-voltage measurements. Also, it will be necessary to zero the measuring instrument often if thermal drift is noted.

## 2.5.14 Cumulative Power

Each signal pathway of the test fixture is rated at 200V, 1A peak. Since there are 72 pathways, it is obvious that the theoretical total power that could be dissipated by device(s) in the fixture is extremely high. Note, however, that there is a practical limit as to how much cumulative power can be safely dissipated within the test fixture. To avoid fixture damage, restrict cumulative power so that the operating temperature of the fixture does not exceed the value stated in the specifications at the front of this manual.

### CAUTION

**Exceeding the recommended operating temperature may cause fixture damage.**

## 2.5.15 AC Measurements

The equivalent ac circuit of the test fixture is especially important to those making ac measurements. For that reason, typical specifications for insertion loss, crosstalk, and 3dB bandwidth are summarized at the front of this manual. An overview of how to go about testing these aspects of fixture performance are summarized in paragraph 3.2.7.

## 2.6 TYPICAL APPLICATIONS

The following paragraphs discuss several typical applications for using the Model 8007 along with the Model 7072 Semiconductor Matrix Card.

### 2.6.1 CV Measurements

CV (capacitance-voltage) measurements are often made on semiconductor devices in order to determine important semiconductor parameters such as doping profile, band bending, and mobile ion concentration. The following paragraphs discuss a typical CV system and typical CV curves.

#### Typical System Configuration

Figure 2-23 shows a typical system for making CV measurements on a device with several elements requiring testing. System components perform the following functions.

**Model 590 CV Analyzer:** Measures CV data at 100kHz and 1MHz and sends the resulting data to the computer for further analysis.

**Model 595 Quasistatic CV Meter:** Measures quasistatic CV data and sends the data to the computer.

**Model 707 Switching Matrix:** Controls the Semiconductor Matrix Card to close and open the desired crosspoints at the proper time.

**Model 7072 Semiconductor Matrix Card:** Switches the signal pathways to the device elements under test.

**Computer:** Controls the instruments in the test system using appropriate software.

**HPGL Plotter:** Provides hard copy graphs for the tests.

**Model 8007 Test Fixture:** Holds the device package being tested and provides the interconnection interface between the instruments and the device.

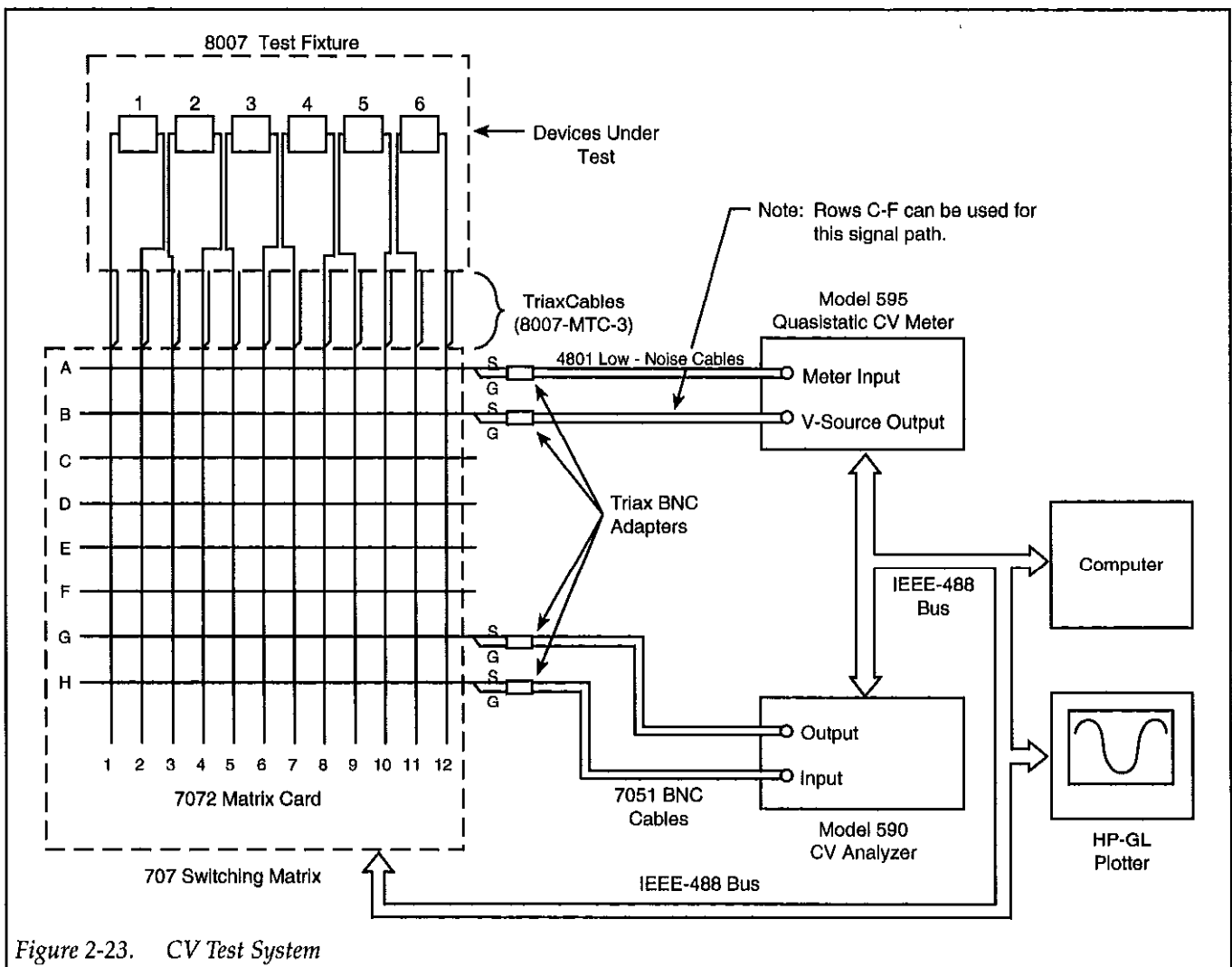

Figure 2-23. CV Test System

### Typical CV curves

Typical CV curves generated by the Models 590 and 595 are shown in Figure 2-24 and Figure 2-25 respectively. The quasistatic curve is almost symmetrical, while the high-frequency curve is asymmetrical because of the inability of the minority carriers to follow the high-frequency test signal.

### CV Measurement Considerations

High-frequency CV measurements are made using a 100kHz or 1MHz test signal that can be affected by the distributed capacitance of the connecting cables and test fixture. In order to compensate for these effects, the Model 590 includes software cable correction algorithms to optimize measurement accuracy. Cable correction should always be used when making high-

frequency CV measurements using the Model 8007 Test Fixture.

When cable correcting the test system, be sure that the test fixture cables are connected properly and that the test fixture lid and ZIF sockets are closed (closing the ZIF sockets can affect stray capacitance). Also, the device under test must be removed from the socket when cable correction is performed. See the Model 590 Instruction Manual for complete details on cable correction.

In a similar manner, the quasistatic CV measurements made by the Model 590 are subject to errors caused by leakage currents in the system. In order to minimize these errors, it may be necessary to use the corrected capacitance feature of the Model 590; see the Model 590 Instruction Manual for details.

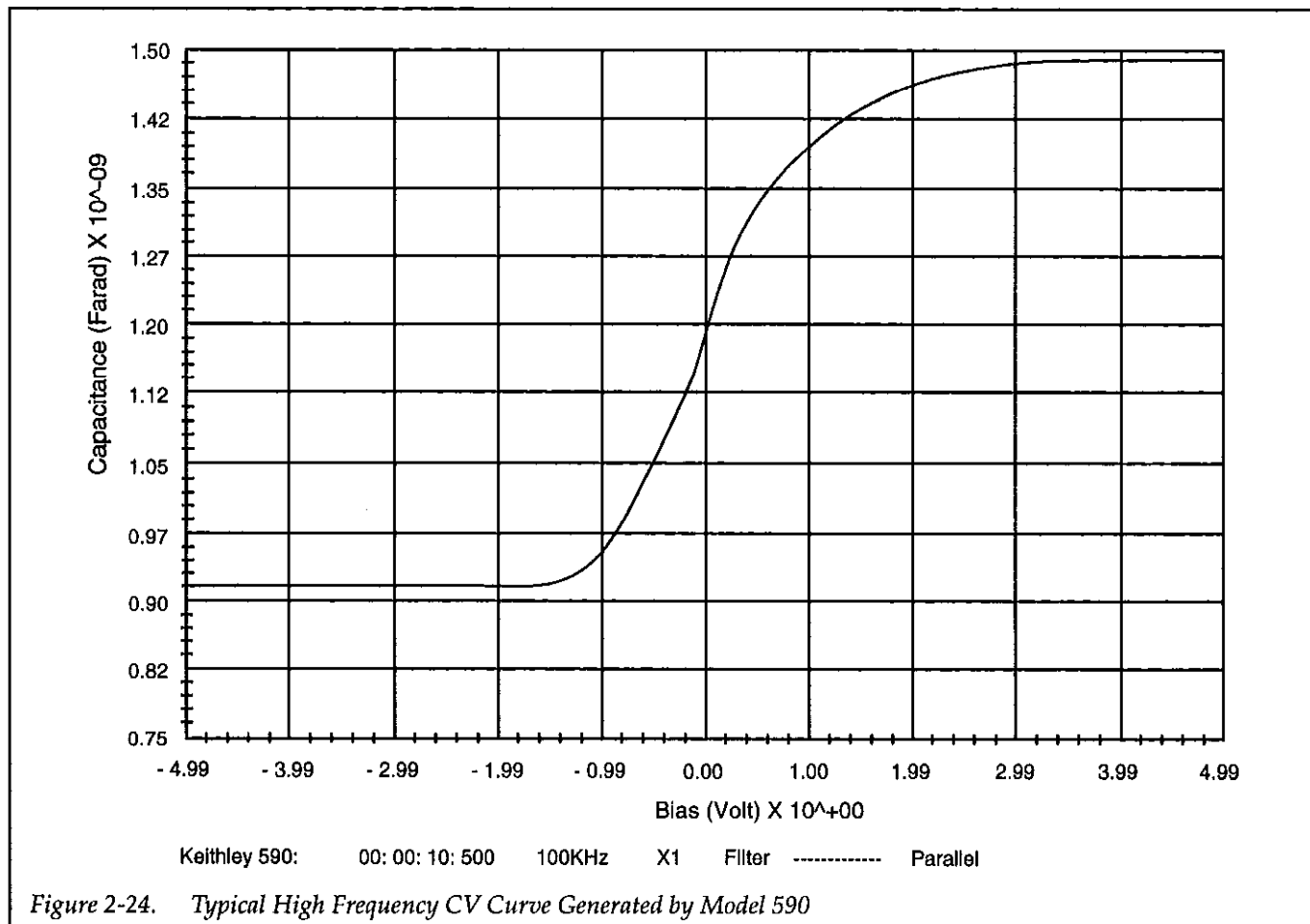

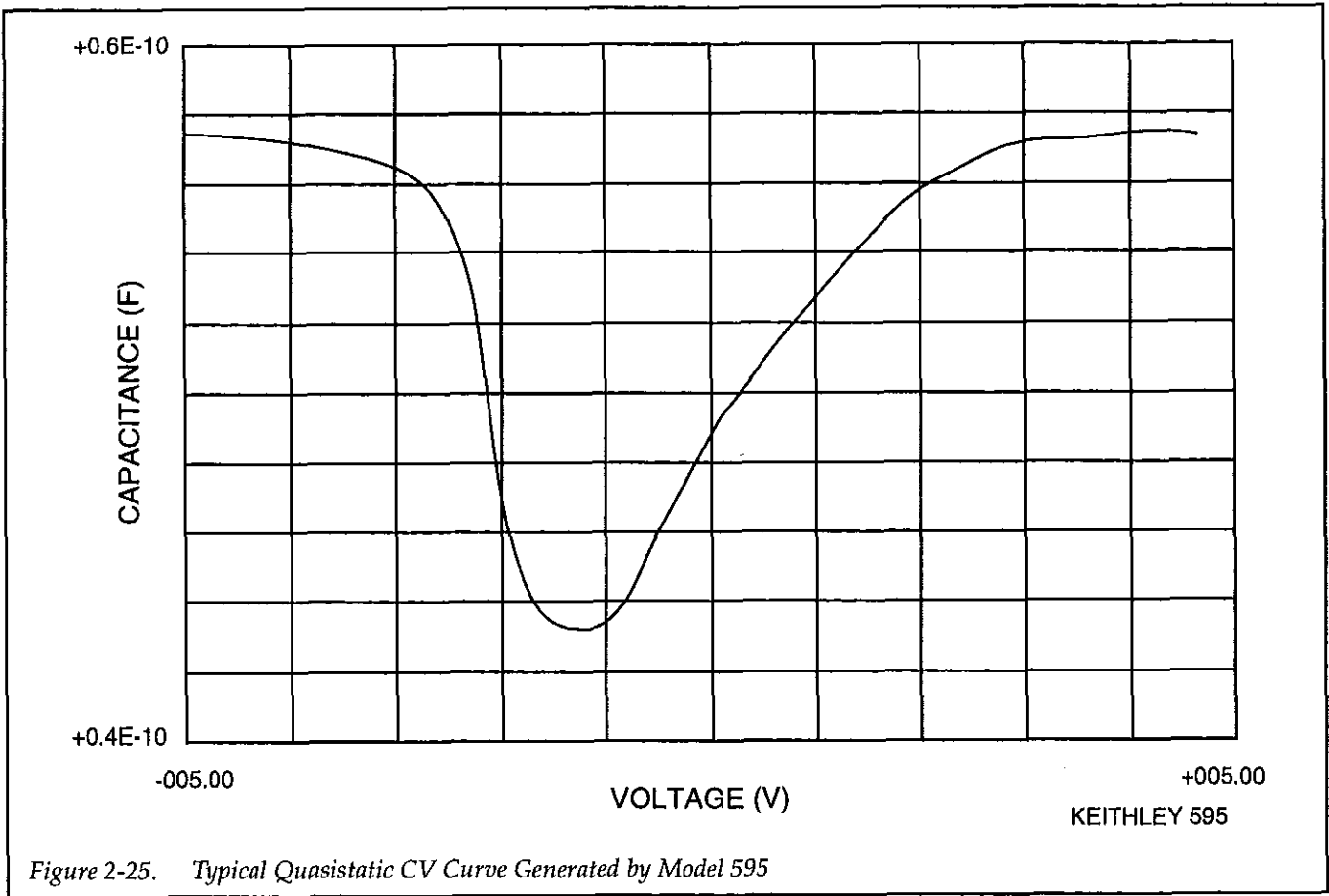

Figure 2-25. Typical Quasistatic CV Curve Generated by Model 595

## 2.6.2 FET Testing

FET devices are often tested to determine such parameters as common-source characteristics. These characteristic curves can yield much important information about packaged FET devices. A typical test system and example curves are discussed below.

### Test System

Figure 2-26 shows a typical system for testing FETs. The various components in the system perform the following functions as pictured in Figure 2-27.

Model 617 Electrometer/Source: Measures  $I_D$  (drain current) and sources  $V_{DS}$  (drain-source voltage).

Model 230 Voltage Source: Sources  $V_{GS}$  (gate-source voltage).

Model 7072 Semiconductor Matrix Card: Routes the test signals to the particular FET under test.

Model 707 Switching Matrix: Controls the matrix card to open or close crosspoints as required.

### Typical Common-Source Characteristics

Typical common-source characteristics are shown in Figure 2-28. Such curves are generated by setting  $V_{GS}$  to specific values (for example, in increments of 0.25V), and then stepping  $V_{DS}$  across the desired range while measuring  $I_D$ .

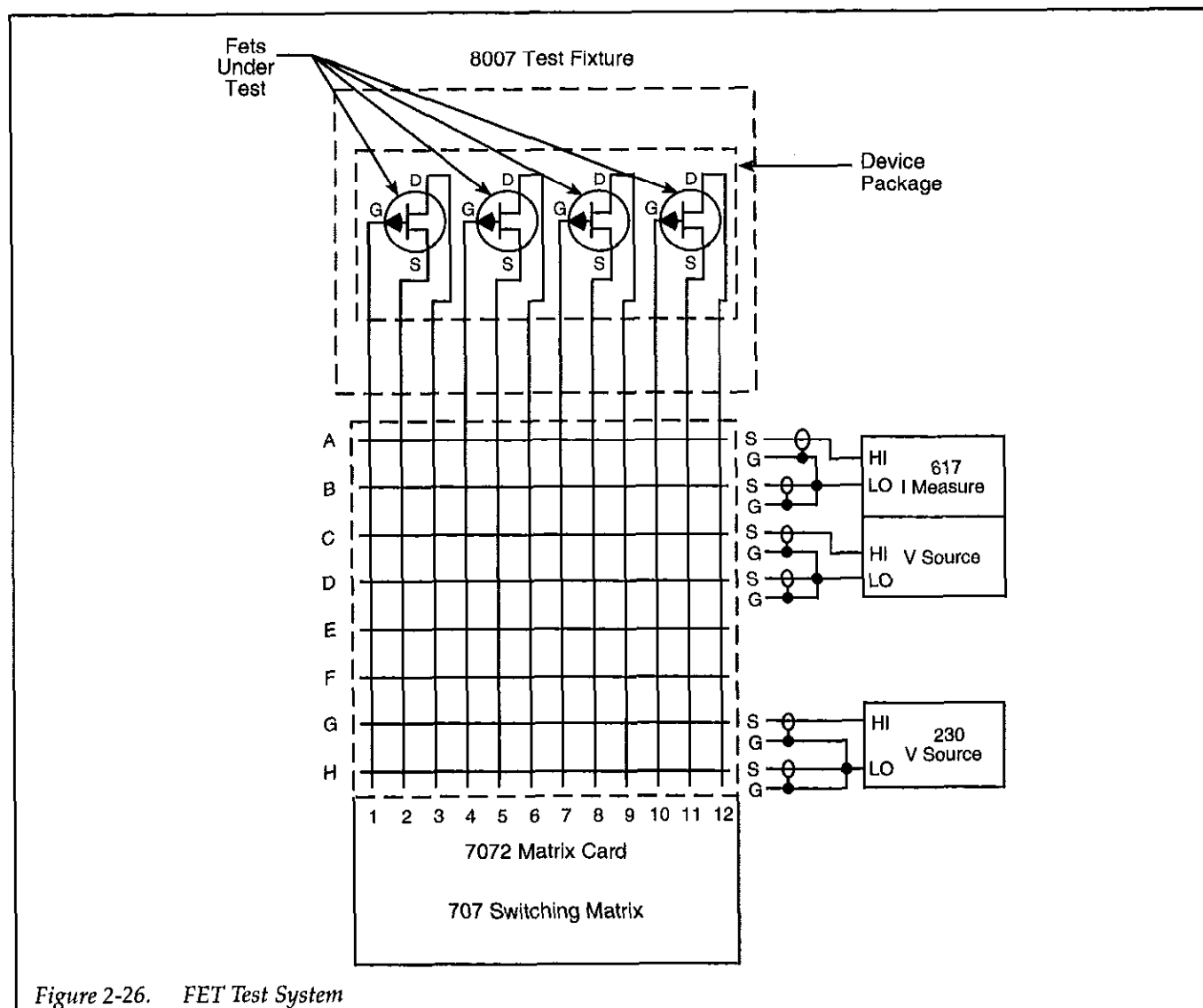

Figure 2-26. FET Test System

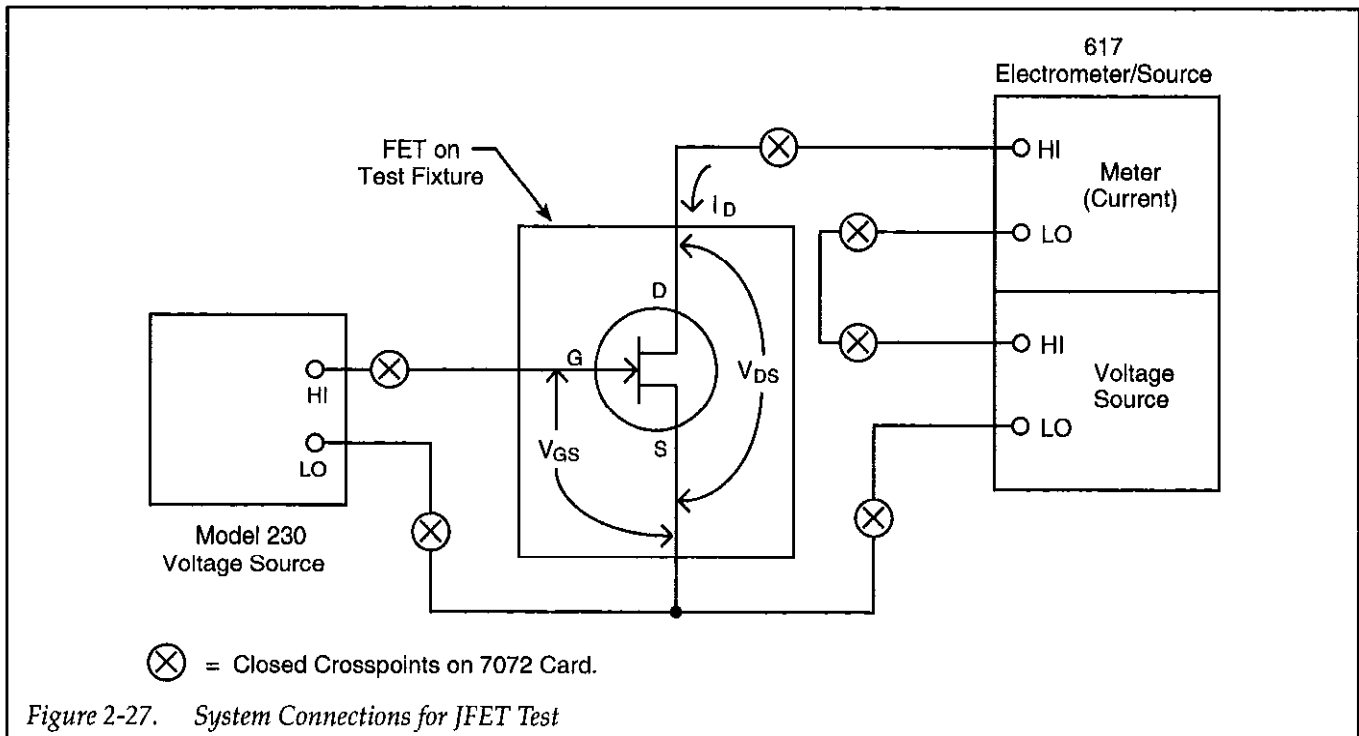

Figure 2-27. System Connections for JFET Test

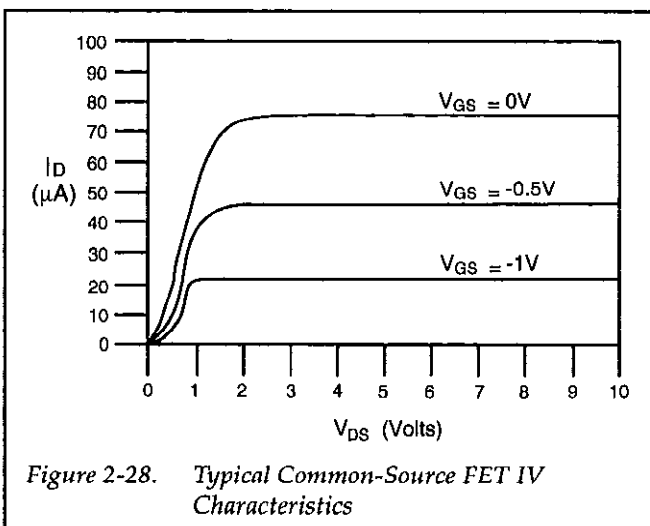

Figure 2-28. Typical Common-Source FET IV Characteristics

### 2.6.3 Semiconductor Parameter Analysis

A semiconductor parameter analysis switching system is capable of complete dc characterization of semiconductors. The following paragraphs outline a typical system for such analysis.

#### System Configuration

Figure 2-29 shows the general configuration of a semiconductor test switching system. The various parts of the system operate as follows:

**HP4145B Semiconductor Parameter Analyzer:** The SPA has four source measure units, two voltage sources, and two voltmeters. Each source measure unit can source voltage and measure current, or source current and measure voltage.

**Model 707 Switching Matrix:** Controls the matrix card to open and close signal paths as required.

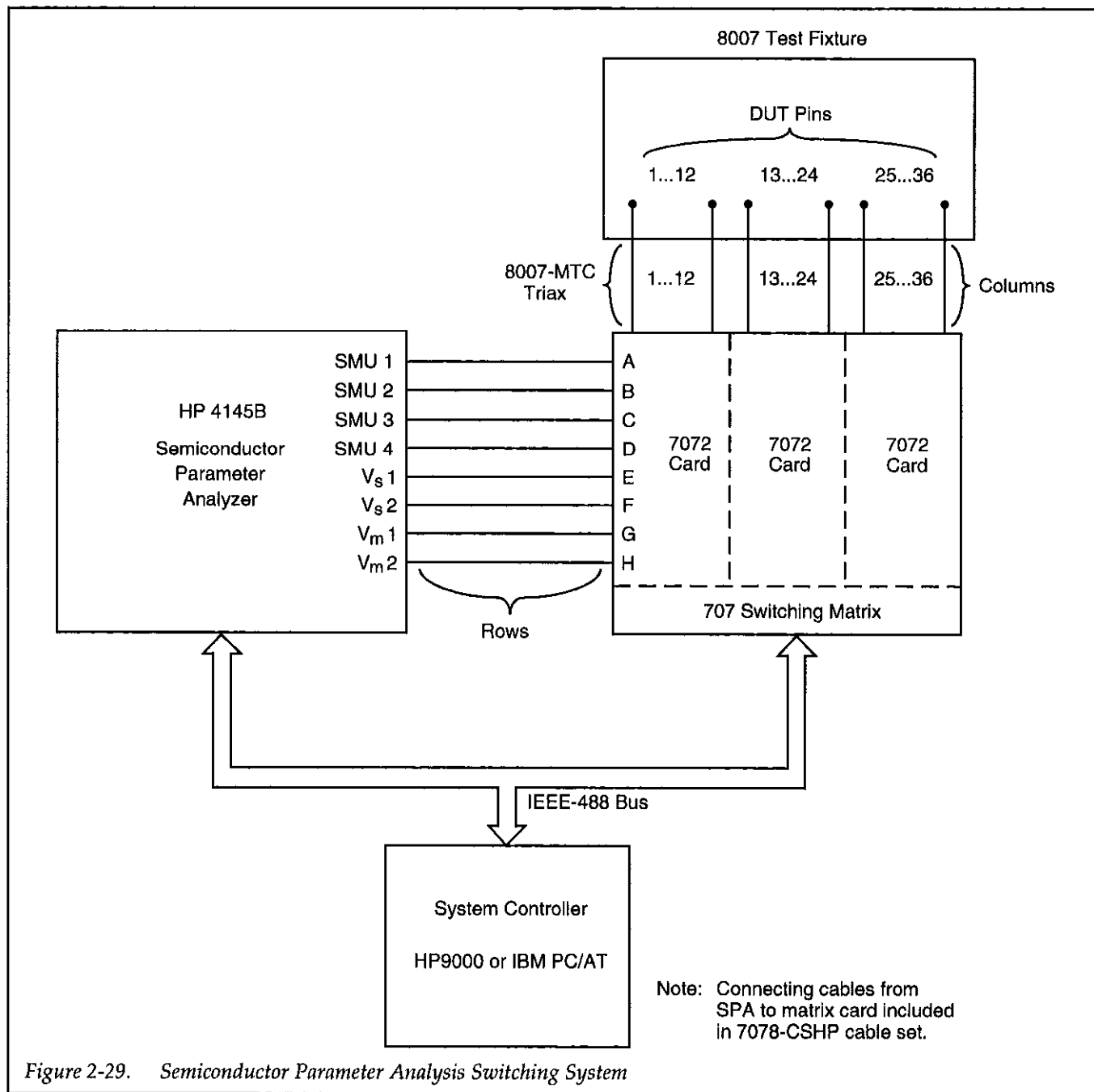

Figure 2-29. Semiconductor Parameter Analysis Switching System

Model 7072 Semiconductor Matrix Card: Switches the test pathways to the device under test. In this particular application, three matrix cards provide 36-pin test capability. For more complex applications, a total of six cards can be installed in one mainframe, providing up to 72-pin switching capability in one mainframe.

System Controller: Controls the SPA and switching matrix using appropriate software. Typical controllers are HP 9000 Series 200 or 300 (with HP-IB interface), and IBM PC, AT, or compatible computers (equipped with an IEEE-488 interface).



Model 8007 Test Fixture: Provides the connection interface between the device under test and the matrix card.

### Typical Test Configuration

A typical test configuration for determining the current gain of a bipolar transistor is shown in Figure 2-30. Source measure unit #1 is used to set the base current,  $I_B$ , for a specific value of collector current,  $I_C$ . Source measure unit #2 is used to set  $V_{CE}$  to the desired value and also measure  $I_C$ . The current gain,  $\beta$  is then calculated as follows:

$$\beta = \frac{I_C}{I_B}$$

## 2.7 USING THE PROTOTYPING BOARD

### WARNING

User-supplied lethal voltages may be exposed when the lid is open. Safe operation requires the use of the safety interlock (see paragraph 2.2.1)

### NOTE

When using the prototyping board, specifications may be substantially degraded depending on cleanliness and environmental conditions such as humidity.

### 2.7.1 Board Wiring

Figure 2-31 shows the general configuration of the prototyping board. The circuit board has .04" diameter holes on 0.1" centers. These holes will accept standard IC packages, as well as mounting terminals such as micro clips and vector pins. After installation, all components or terminals should be soldered in place to assure good connections.

In order to complete wiring, you must connect appropriate points of your circuit to the input/output pads or terminals on the prototyping board using jumper wires. Wires can either be soldered to the adjacent pads or wire-wrapped to the terminals. These pads and terminals are arranged around the two ZIF socket pin groups, and they are numbered for convenience.

### 2.7.2 Board Cleaning

Flux left on the circuit board after soldering can degrade measurements, especially those of the high-impedance variety. After soldering to the prototyping board, the board should be carefully cleaned as follows:

1. Carefully clean the soldered areas using Freon® TMS or TE or the equivalent. Clean cotton swabs or a clean, soft brush can be used to help remove the flux. Be careful not to spread the flux around to other areas of the board.

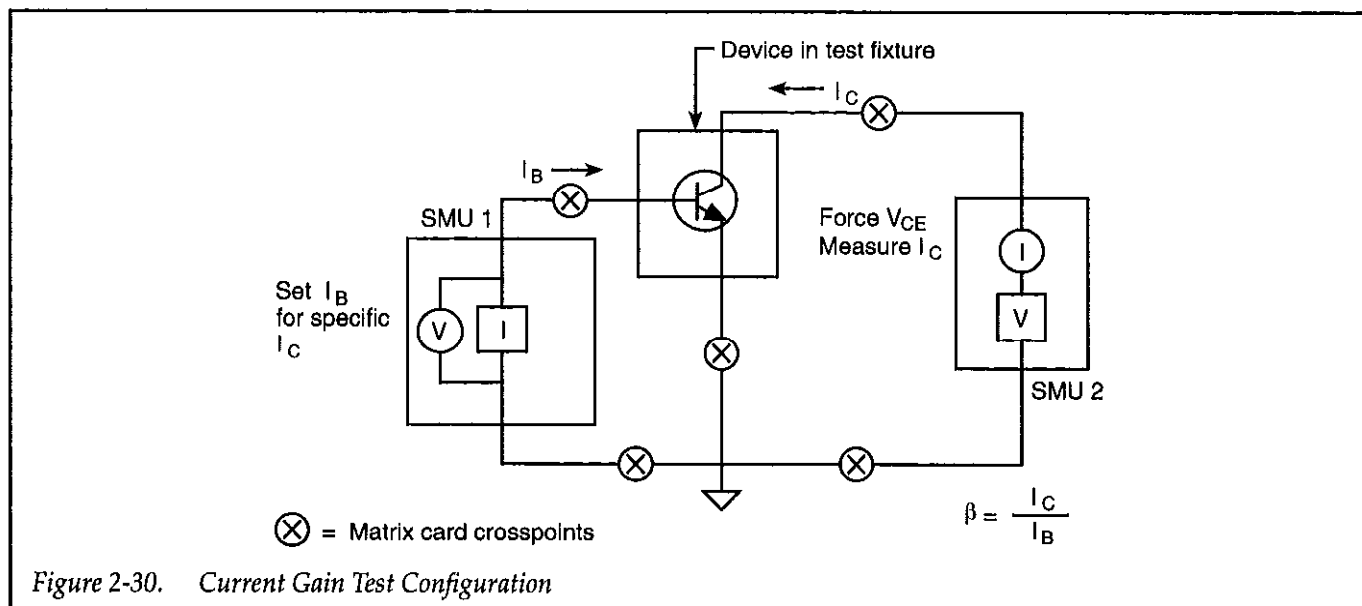

Figure 2-30. Current Gain Test Configuration

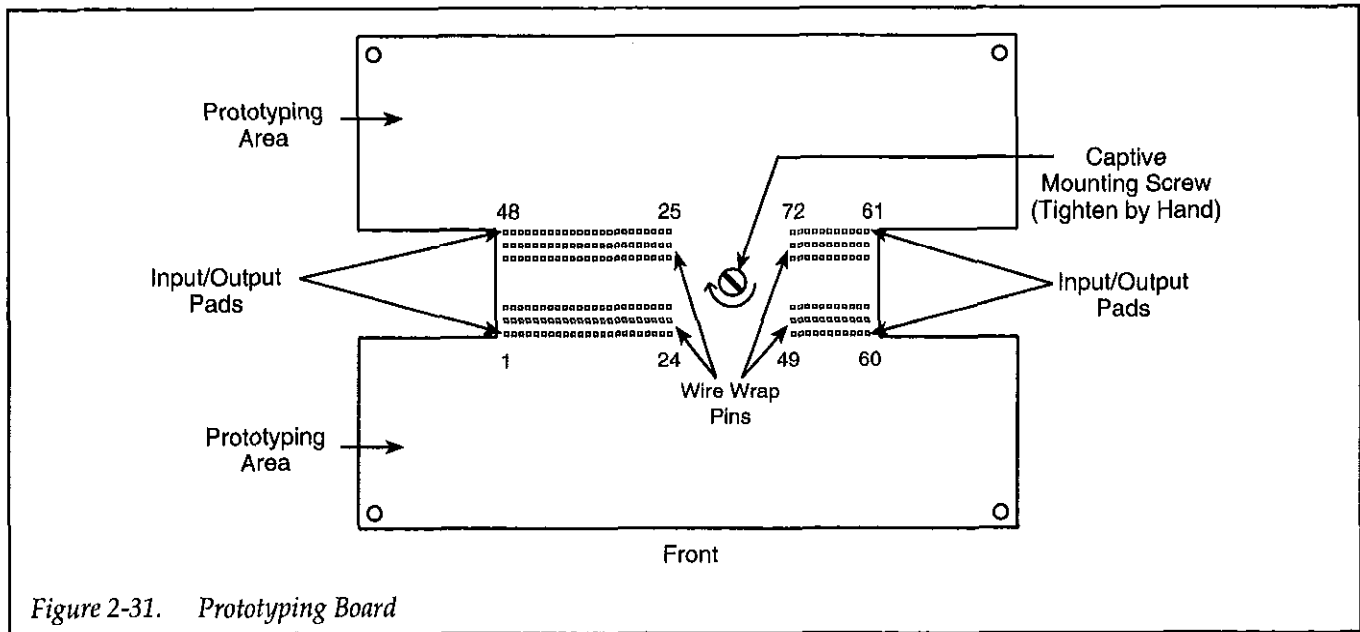

Figure 2-31. Prototyping Board

2. After cleaning with Freon®, swab the treated area with clean methanol, then blow dry the board with dry nitrogen gas.
3. After cleaning the board, allow it to dry for several hours in a 50°C, low-humidity environment before use.

**NOTE**

After cleaning, be careful not to contaminate the board surfaces by touching them with your hands. Handle the board only by the edges.

**2.7.3 Board Installation**

After constructing your circuits on the prototyping board, mount it on the test fixture by first setting the ZIF sockets to the open position, and then carefully lining up the pins in the board with the corresponding socket holes, as shown in Figure 2-32. Once the pins are lined up, seat the board on the top panel of the test fixture, then tighten the captive mounting screw to secure the board to the front panel. Move the socket levers to the closed position.

**NOTE**

Tighten the screw only finger tight; do not use a screwdriver (a screwdriver may be used to loosen the screw if necessary).

To remove the board, first loosen the screw and move the socket levers to the open position. Pull up on the

board until it is free of the sockets. Be sure to handle the board only by the edges to avoid surface contamination.

**2.7.4 Prototyping Board Considerations**

The guard pathways present on the main circuit board are not carried through to the prototyping board. As a result, the offset current and path insulation specifications for the test fixture given at the front of this manual do not apply when using the prototyping board. For that reason, prototyping board tests should be limited to less critical (lower impedance) circuits than conventional test fixture measurements.

**2.7.5 Wiring Kelvin Connections on the Prototyping Board**

One possible use for the prototyping board is for Kelvin or 4-wire connections. Such connections are usually used with remote sensing instruments such as source/measure units.

Figure 2-33 shows typical Kelvin connections wired on the prototyping board. Note that two terminals of the DUT are connected to two pathways via jumpers to the wire wrapping terminals.

Incidentally, you can also wire Kelvin connections directly on the sockets. Simply route the sense leads to unused socket terminals and add jumpers as shown in Figure 2-34. Be certain that the jumper wires have the same diameter as the DUT pins so that good connections are made both to the DUT and jumpers.

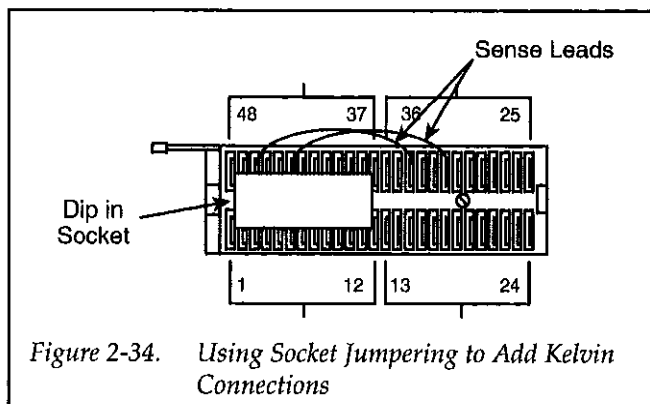
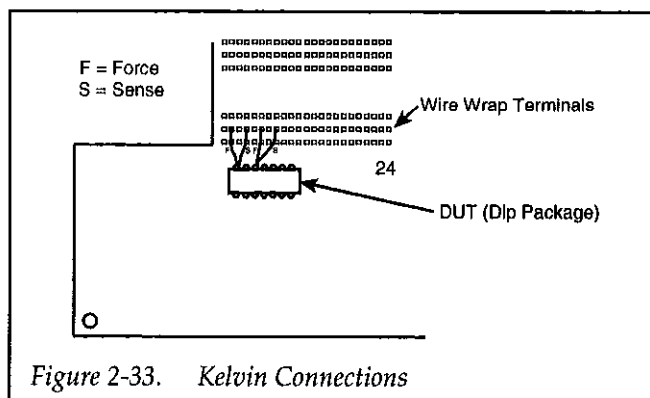
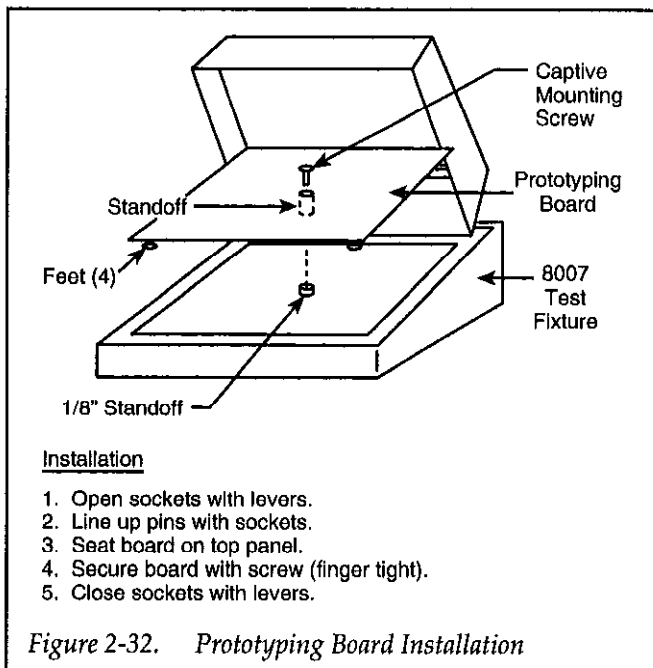



# SECTION 3

## Service Information

---

### 3.1 INTRODUCTION

This section contains information on servicing the Model 8007 Test Fixture, and it is arranged as follows.

**3.2 Performance Verification:** Outlines the procedures necessary to verify that the test fixture meets important stated specifications.

**3.3 Handling and Cleaning Precautions:** Details methods to clean fixture board surfaces and connectors to remove contamination that could affect performance.

**3.4 Disassembly:** Covers disassembly of the Model 8007.

**3.5 Interlock Switch Calibration:** Covers the procedure to adjust the clearance for the interlock switch.

**3.6 Pathway Modification:** Discusses techniques for modifying pathways by installing custom components.

**3.7 Binding Post Installation:** Covers installation procedures for installing binding posts in the plugged 3/8" holes.

#### WARNING

The information in this section is intended only for qualified service personnel. Some

of the procedures may expose you to hazardous voltages that could result in personal injury or death. Do not attempt to perform these procedures unless you are qualified to do so. Perform all tests with the fixture lid closed to ensure safe operation.

### 3.2 PERFORMANCE VERIFICATION

Performance verification can be performed to check to see that the test fixture meets its stated specifications, as described in the following paragraphs.

#### 3.2.1 Environmental Conditions

All tests should be performed at an ambient temperature between 18° and 28°C and at a relative humidity of less than 60% unless otherwise noted. If the test fixture has been subjected to temperature or humidity extremes, allow the unit to environmentally stabilize for at least one additional hour before beginning the tests.

#### 3.2.2 Recommended Test Equipment

Test equipment recommended for the performance verification tests are summarized in Table 3-1.

Table 3-1. Recommended Test Equipment

Qty.	Description	Specifications	Application
1	Keithley Model 617 Electrometer	2pA, $\pm 1.6\%$	Path isolation/offset current
1	Keithley Model 199 DMM	300 $\Omega$ , $\pm 0.1\%$	Path resistance
1	Keithley Model 8007-MTC-3 Cable		All
1	Pomona 5299 3-lug Triax to BNC Adapter		Path resistance /isolation
1	Pomona 1894 BNC to Banana Adapter		Path resistance/isolation
1	Model 6172 2-slot to 3-lug Adapter		All
1	4-inch length stranded wire		All
1	3-foot length stranded wire		Path resistance
1	1-inch length bare copper #20 wire		Path resistance

### 3.2.3 Performance Record

Table 3-2 can be used to record the verification results for the pathway pairs being tested. Date, time, and fixture serial number should also be recorded for future reference.

### 3.2.4 Isolation Resistance Verification

Follow the procedure below to verify that isolation resistance between any two given paths meets stated specifications. Should the test fixture fail any path isolation tests, clean the circuit board and connectors, as discussed in paragraph 3.3.

#### Recommended Equipment

- Model 617 Electrometer
- Model 8007-MTC-3 Cable Assembly
- Pomona Model 5299 3-Lug Triax to BNC Adapter
- Pomona Model 1894 BNC Female to Banana Plug Adapter
- Model 6172 2-slot to 3-lug Triax Adapter

- 4in. length of stranded wire

#### Test Connections

Figure 3-1 shows the test connections for the isolation resistance verification tests. Use the Model 8007-MTC-3 mass-terminated triaxial cables to make the connections. First connect the triax cable from one fixture pathway being tested to the HI jack of the Model 617 voltage source using the two Pomona adapters (Model 5299 3-lug triax to BNC; Model 1894 BNC female to banana plug). Connect the triax cable from the other connector to the electrometer INPUT jack (using a Model 6172 2-slot to 3-lug adapter). Finally, connect the 4" length of wire between the LO terminal of the electrometer voltage source and COM, and remove the link between COM and chassis ground (leave the link in place if the measurements are excessively noisy).

#### Procedure

Follow the procedure below to check the isolation resistance between any two given pathways. Instead of checking each possible pathway combination, check only one



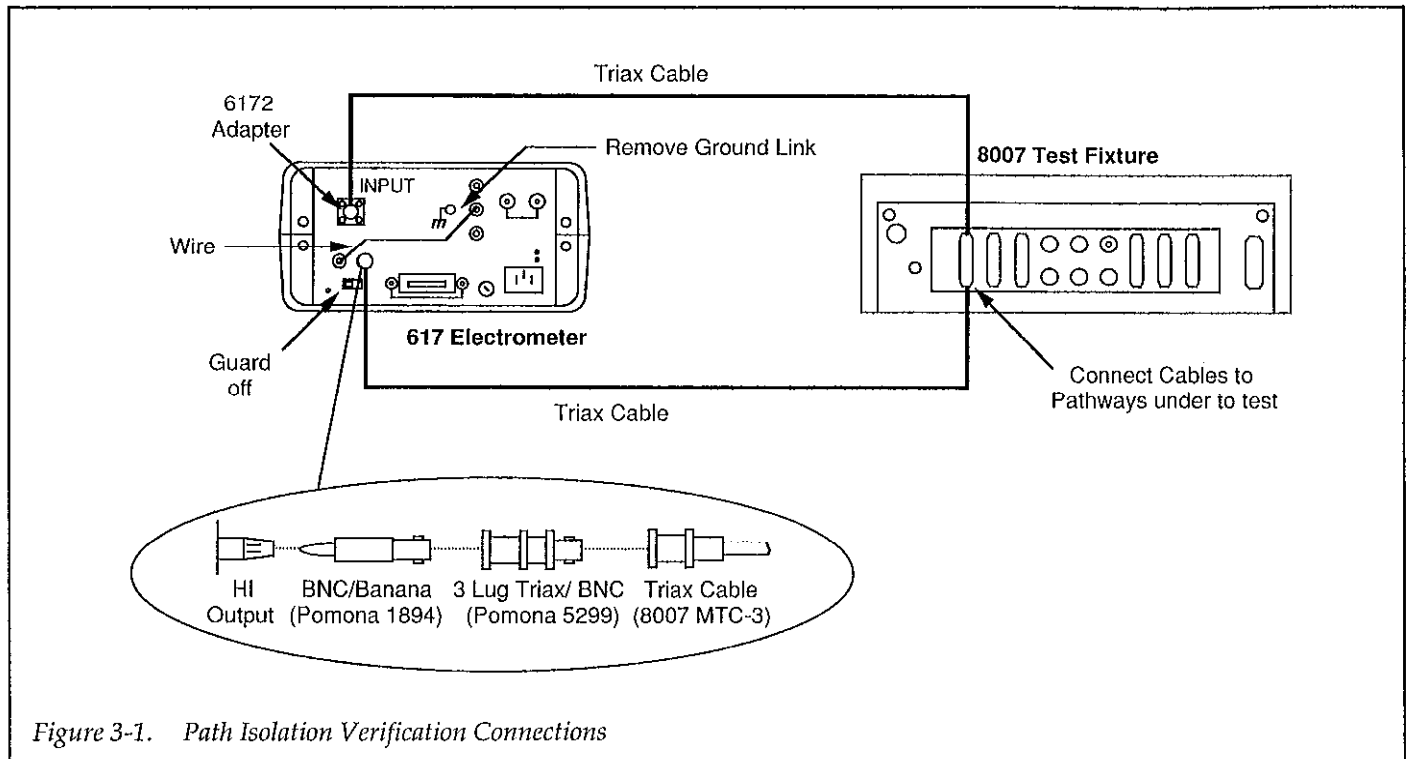

Figure 3-1. Path Isolation Verification Connections

### 3.2.5 Offset Current Verification

#### Procedure

Follow the procedure below to verify that offset current is below specifications. Should the fixture fail the test, clean the circuit board and connectors, as described in paragraph 3.3.

#### Required Equipment

- Model 617 Electrometer
- Model 8007-MTC-3 Triax Cable Assembly
- Model 6172 2-slot to 3-lug Triax Adapter

#### Test Connections

Figure 3-2 shows the test connections for the offset current tests. Note that the pathway being tested should be connected to the INPUT jack of the electrometer through the Model 8007-MTC-3 triax cable assembly and the Model 6172 2-slot to 3-lug adapter. Also, make certain that the link between COM and chassis ground has been removed, and that the V-Ω, GUARD switch is in the OFF position.

1. Turn on the Model 617 Electrometer, and allow the unit to warm up for at least one hour for rated accuracy. Make sure the electrometer is set for the unguarded mode (GUARD off).
2. Select the amps function and the 2pA range on the electrometer, and enable zero check. Zero correct the electrometer by pressing ZERO CORRECT. Leave zero correct enabled for the remainder of the test. After zero correcting the instrument, enable autoranging.
3. Connect the test fixture pathway to the INPUT jack of the electrometer as described above. Make certain that all components have been removed from the device sockets, then close the test fixture lid.
4. Disable zero check, then allow the reading to settle.
5. Verify that the current reading is less than 1pA ( $10^{-12}$ A), and record the reading in Table 3-2 for future reference.
6. Enable zero check, then connect the next pathway to be checked.
7. Repeat steps 4 through 6 for all pathways to be checked.



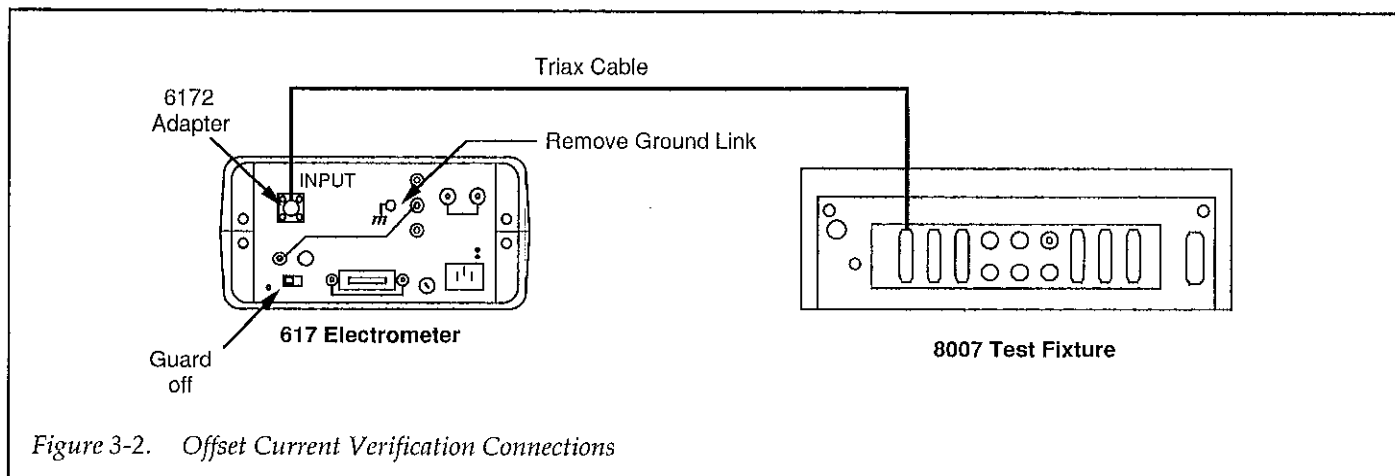

Figure 3-2. Offset Current Verification Connections

### 3.2.6 Path Resistance Verification

The path resistance can be checked to verify that no bad connections exist on any of the pathways. Follow the procedure below to check the path resistance.

#### Required Equipment

- Model 199 DMM
- Model 8007-MTC-3 Triax Cable Assembly
- Pomona Model 5299 3-Lug Triax to BNC Adapter
- Pomona Model 1894 BNC Female to Banana Plug Adapter
- Three-foot length of stranded wire
- One-inch length of #20 AWG bare copper wire

#### Test Connections

Figure 3-3 shows the test connections for the path resistance checks. First, connect the Pomona BNC/banana plug (1894) and 3-lug triax/BNC (5299) adapters to VOLTS/OHMS HI of the DMM (see the inset of Figure 3-3). Connect the triax cable to the DMM, but do not yet connect the test fixture.

For the remaining connection, solder one end of the bare copper wire to one end of the 3-foot length of stranded

wire, then connect the opposite end of the stranded wire to the VOLTS/OHMS LO terminal of the DMM. After soldering, clean all oxidation and flux from the length of bare copper wire.

#### Procedure

1. Turn on the Model 199 DMM and allow the unit to warm up for one hour.
2. Select the ohms function, 300 $\Omega$  range, and 5-1/2 digit resolution on the DMM.
3. Short the end of the bare copper wire to the center conductor of the triax cable connected to the DMM, and allow the reading to settle. Enable zero on the DMM with the two wires shorted together. This step nulls out any residual resistance in the test connections.
4. Connect the triax cable assembly to the test fixture. Also, connect the end of the bare copper wire to the socket terminal for the pathway being tested. Be sure to push the end of the wire into the socket terminal and close the lever to ensure a good connection.
5. Note the resistance reading on the DMM, and verify that the value is less than 1 $\Omega$ . Also record the reading in Table 3-2 for future reference.
6. Repeat steps 3 through 5 for all pathways being tested.

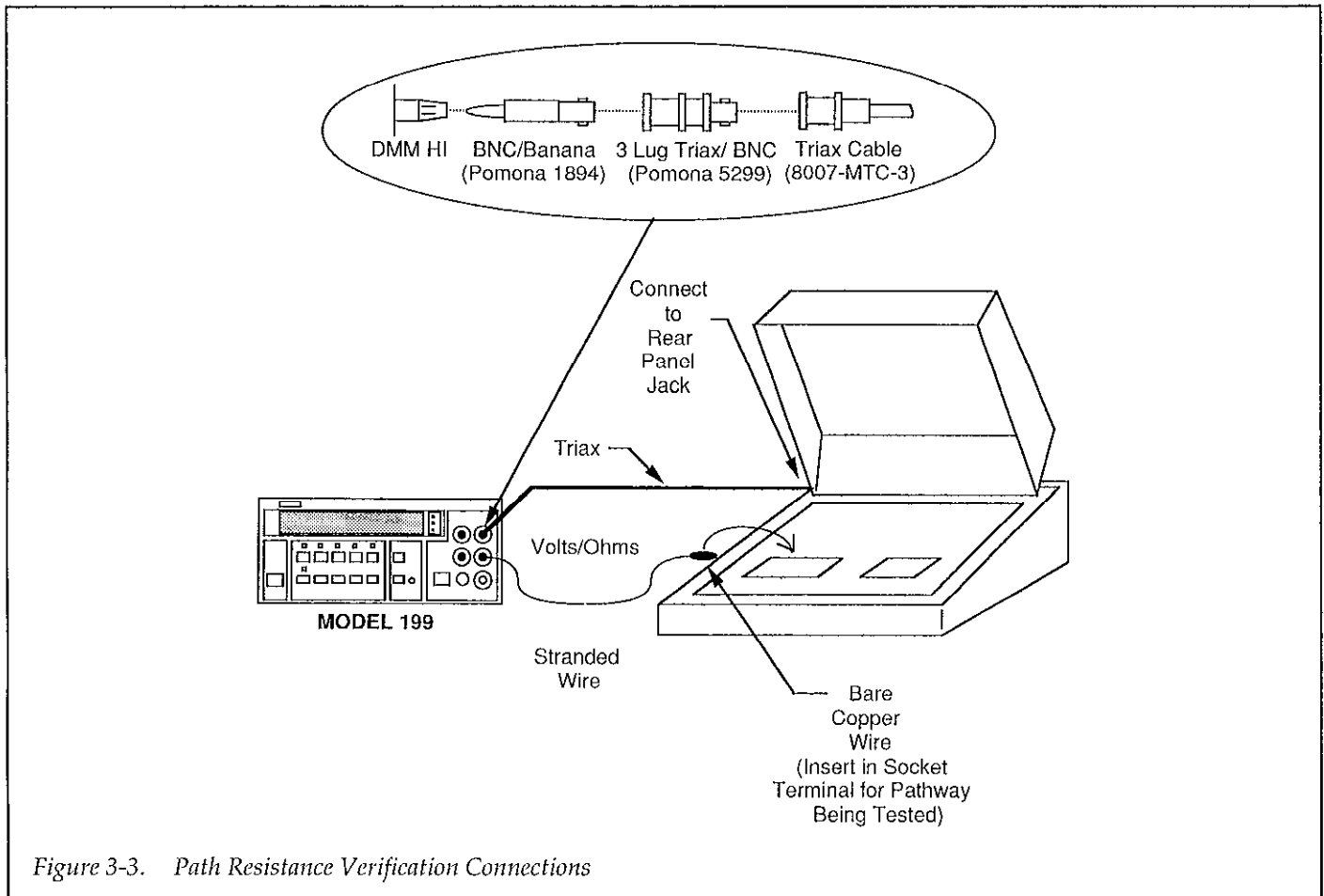

Figure 3-3. Path Resistance Verification Connections

### 3.2.7 AC Performance

AC performance aspects such as insertion loss, crosstalk, and 3dB bandwidth need not normally be tested as part of the verification procedure. However, those who are interested in characterizing the performance of their test fixture can do so as outlined below. Insertion loss, 3dB bandwidth, and crosstalk specifications are located in the specifications at the front of this manual.

**NOTE**

Insertion loss, 3dB bandwidth, and crosstalk specifications are typical.

#### Equipment

In order to test AC performance, a network analyzer or separate RF signal generator and voltmeter or oscillo-

scope will be necessary. This equipment should have the following basic specifications:

- Source frequency: 1MHz and 4MHz
- Source output impedance: 50Ω
- Measure frequency: 1MHz and 4MHz
- Measure input impedance: 50Ω and 1MΩ selectable

#### Test Connections

Figure 3-4 show the test connections for AC tests. Since most RF instruments are equipped with BNC jacks, it will be necessary to use triax/BNC adapters (Pomona 5299) to connect the Model 8007-MTC-3 cables to the test equipment.

**WARNING**

The outer shell of the triax connectors must be connected to measurement LO to avoid a possible shock hazard. Also, connect the ter-

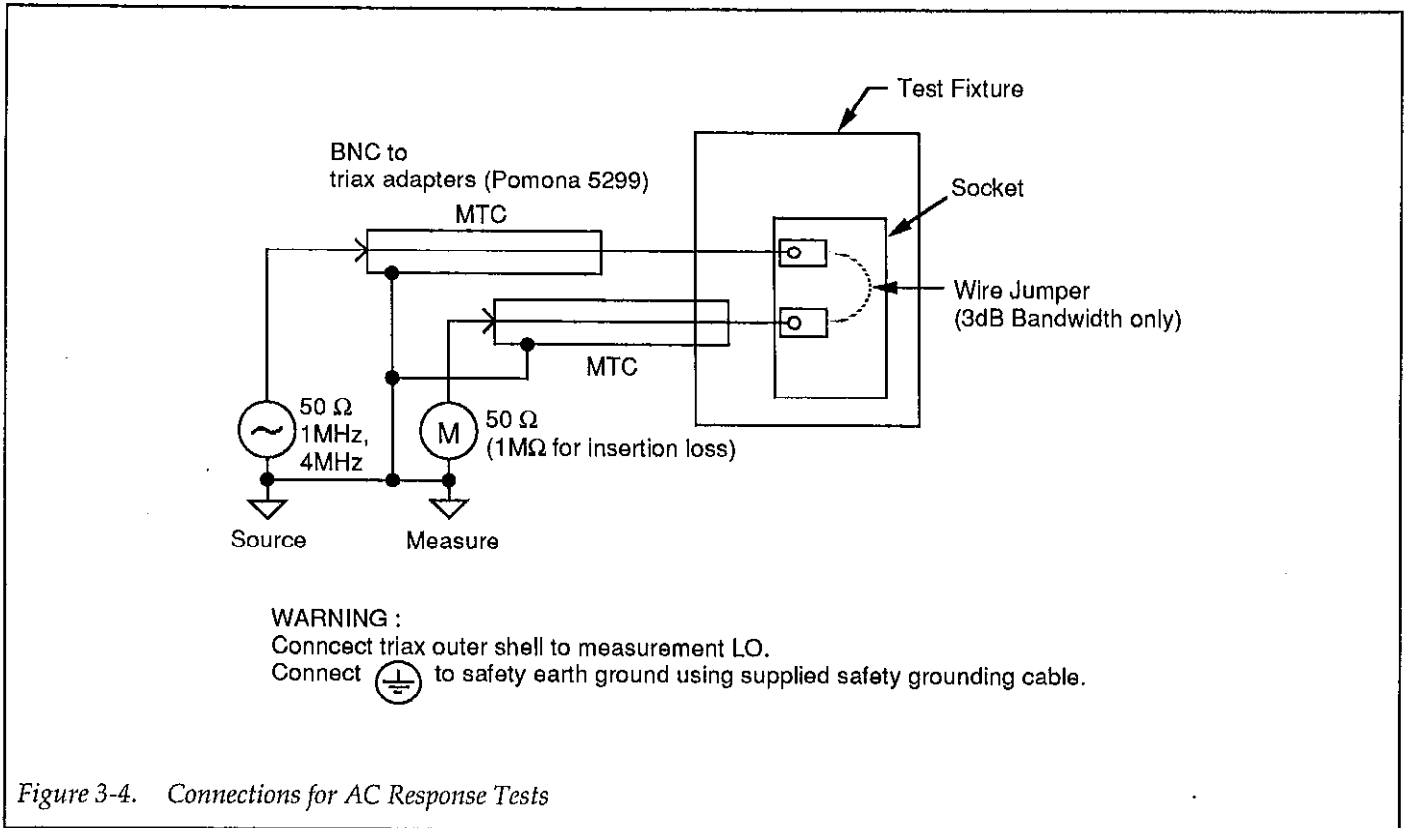

Figure 3-4. Connections for AC Response Tests

terminal of the test fixture to safety earth ground using the supplied safety grounding cable before measuring.

### 3dB Bandwidth

For this test, both source and measure impedance are 50Ω. Set the source frequency to 4MHz, and the measurement device as appropriate. Install a jumper in the DIP socket between the two pathways being tested, and close the DIP socket.

### Crosstalk

For this test, both source and measure impedance are 50Ω, and the test frequency is 1MHz. Remove the jumper between socket terminals, and test between adjacent terminals. Doing so will give you worst-case results because adjacent socket terminals have the highest capacitance.

### Insertion Loss

To test insertion loss, set the signal generator to 1MHz with an output impedance of 50Ω. Remove the jumper, and measure the insertion loss with a 1MΩ input impedance directly at the socket terminal with the ZIF socket in the close position (for worst case, highest capacitance measurements).

Note that the measurement must be made directly at the socket terminals because the connecting triax cables have a characteristic impedance of 50Ω, and the measurement is specified with a load impedance of 1MΩ. Insertion loss is a measurement of what the device sees regardless of impedance. The 1MΩ measurement may yield slightly better results than a 50Ω measurement, but typically not more than a 0.5dB improvement.

## 3.3 Handling and Cleaning Precautions

Because of the high-impedance areas on the Model 8007 circuit board and prototyping board, care should be taken when handling or servicing the fixture to prevent possible contamination that could degrade performance.

### 3.3.1 Board Handling and Cleaning

The following precautions should be taken when handling the test fixture circuit board.

1. When removing the board from the unit, handle the board only at the edges whenever possible. Do not touch any board surfaces or components not associated with component or jumper installation.
2. Do not store or operate the test fixture in an environment where dust could settle on the circuit boards or connectors. Use dry nitrogen gas to clean dust off the circuit boards and connectors if necessary.
3. After soldering to the circuit board, remove flux from soldered areas using Freon® TMS or TE (or the equivalent) dipped in clean cottons swabs or a clean, soft brush. When cleaning, take care not to spread the flux to other areas of the circuit board. Once the flux is removed, swab only the soldered area with methanol, then blow dry the board with dry nitrogen gas.
4. After cleaning, the fixture should be placed in a 50°C low-humidity environment for several hours before use.

### 3.3.2 Connector Cleaning

Connectors are also subject to performance degradation caused by contamination due to dirt build-up or im-

proper handling. Connectors can be cleaned with methanol dipped in a cotton swab. After cleaning, allow connectors to dry for several hours in a 50°C low-humidity environment before use.

### 3.4 Disassembly

#### WARNING

Turn off all power and disconnect all cables from the test fixture before disassembly.

#### 3.4.1 Fixture Disassembly

Refer to Figure 3-5 and Figure 3-6, and disassemble the test fixture as follows.

1. Remove the sub chassis by first loosening the two rear screws and four fasteners (pry up with screwdriver) that secure it to the fixture chassis, and then remove the sub chassis through the top panel (see Figure 3-5).
2. Remove the screws that secure the bottom panel to the chassis, then remove the panel. Two screws are located at the bottom front, and the remaining screws are located on the rear panel near the top corners.
3. Remove the screws that secure the top cover to the hinges, then remove the top cover.

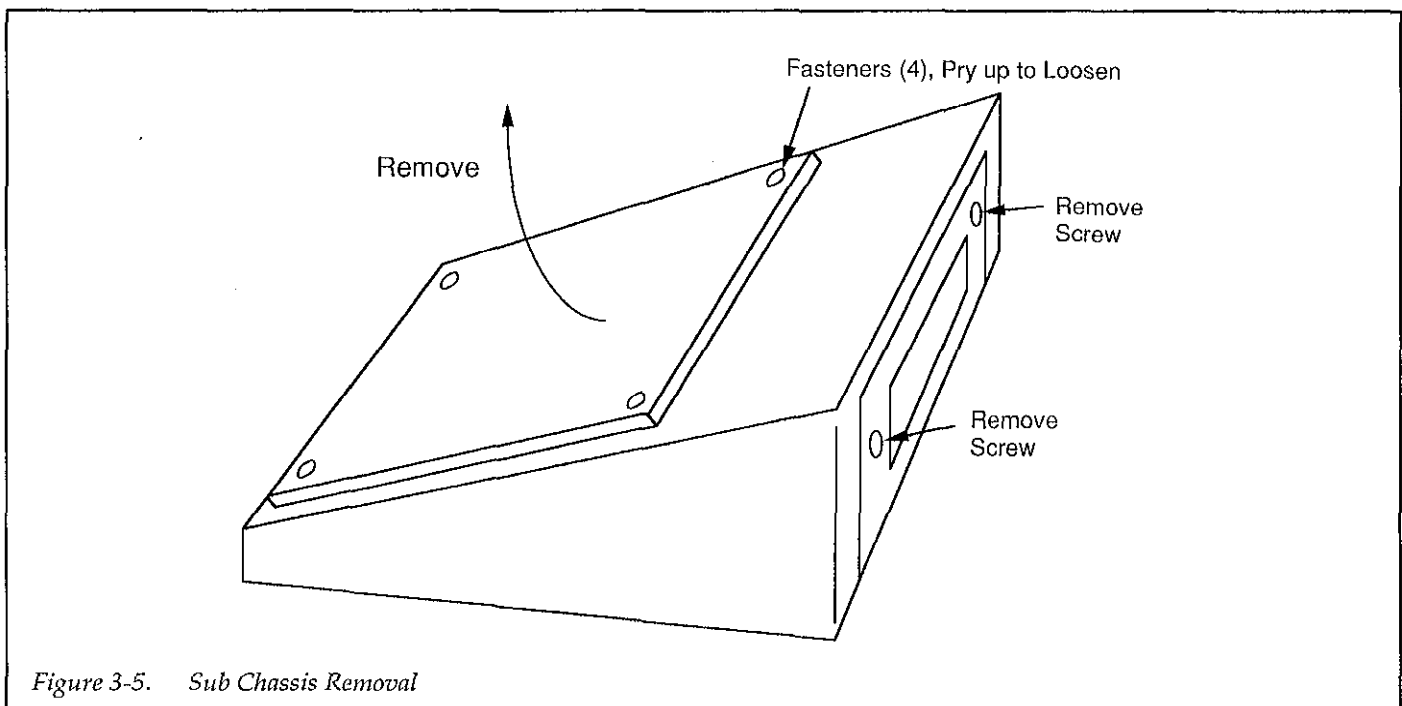

Figure 3-5. Sub Chassis Removal

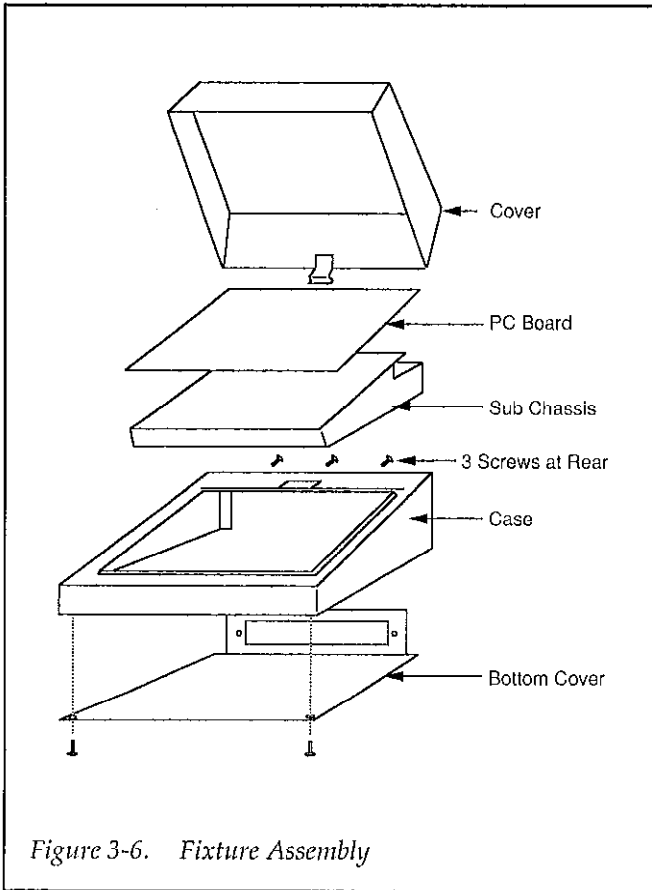

Figure 3-6. Fixture Assembly

**NOTE**

If the hinge screws are loosened, the interlock switch must be calibrated, as discussed in paragraph 3.5.

### 3.4.2 Sub Chassis Disassembly

Refer to Figure 3-7 and disassemble the sub chassis as follows.

1. Remove the four nuts that hold the bottom shield and front panel together, then separate the two halves of the sub chassis.
2. Disconnect the individual cable connectors at the circuit board as required.
3. To remove the circuit board from the sub chassis, first remove the securing screws (6), then separate the sub chassis and circuit board.

**Reassembly Notes**

1. When installing the sub chassis, make certain that all screws are properly installed to ensure proper earth

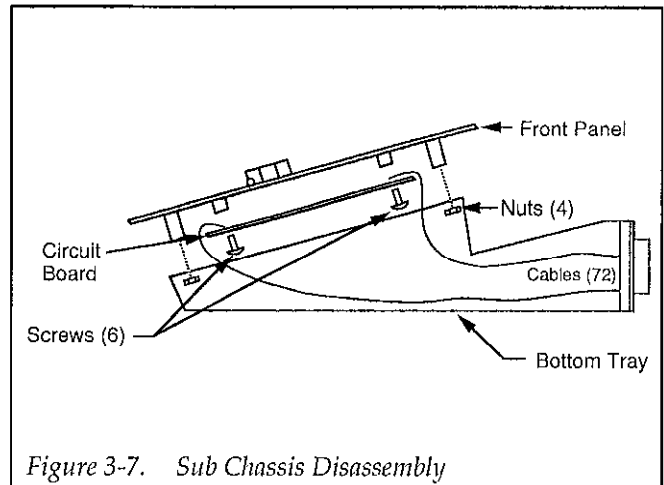

Figure 3-7. Sub Chassis Disassembly

grounding. Make sure that all cables are dressed to ensure no contact with the circuit board.

**WARNING**

All the screws that secure the sub chassis to the fixture body must be installed to ensure a proper safety earth ground (the two rear screws are especially critical for proper grounding of the rear panel to the base).

2. To assemble the lid to the base, first make sure the lid is properly aligned (centered) with the light-tight gasket trough on the base (see Figure 3-8). Tighten all hinge screws securely while making sure the lid remains centered. Check for smooth operation without interference throughout the entire range of motion. After reassembly, calibrate the safety interlock switch, as discussed in the following paragraph.

**WARNING**

Be sure the lid grounding link is installed under the hinge.

### 3.5 INTERLOCK SWITCH CALIBRATION

Follow the procedure below to make certain that the safety interlock switch operates properly. This procedure must be performed if the hinge screws are loosened for any reason, and it can also be performed if you suspect that the interlock switch does not operate properly. The switch adjustment locations are shown in Figure 3-9.

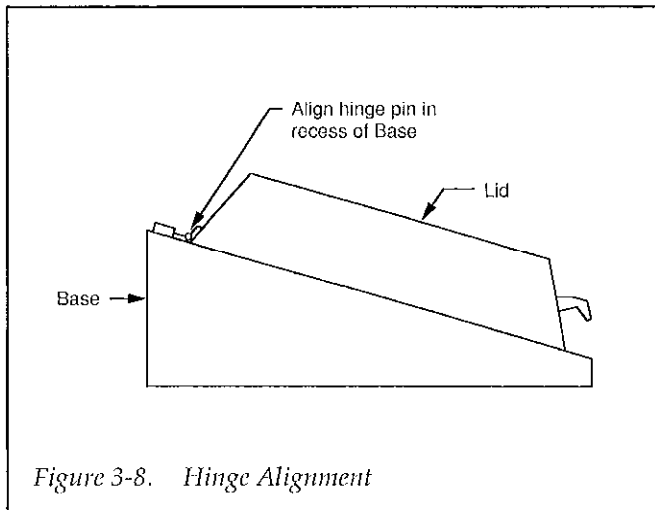

Figure 3-8. Hinge Alignment

1. Remove the bottom cover from the test fixture.
2. Loosen the switch adjustment screws A and B (see Figure 3-9 for locations) just enough to move the switch.
3. Close the top cover on the test fixture, and turn the fixture over.
4. Insert a 0.020" to 0.030" thickness gauge between the operating tang on the back edge of the lid and the switch button.
5. Adjust the interlock switch for a clearance of approximately 0.020" to 0.030" between the operating tang and the switch body, as shown in Figure 3-9. During the adjustment, make sure the lid remains closed securely.
6. Tighten switch adjustment screw A first, then tighten screw B, making certain that the clearance does not change while you are tightening the screws.
7. After adjustment, verify that the switch opens when the front edge of the lid opens between 0.25" and 0.4". Readjust the switch if necessary.
8. Replace the bottom cover, then secure it with the screws removed earlier.

### 3.6 PATHWAY MODIFICATION

**NOTE**

Pathway modification is recommended only for skilled technicians who are familiar with circuit board soldering techniques. Modifying the fixture may degrade performance.

In some cases, you may wish to install components in series with some of the pathways. For example, you may wish to install for current limiting, ferrite beads or resis-

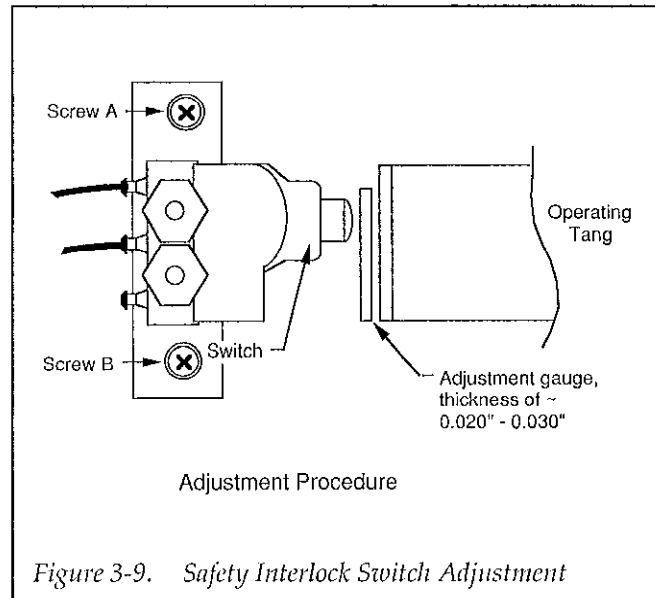

Figure 3-9. Safety Interlock Switch Adjustment

tors to dampen oscillations, as in the example of Figure 3-10.

Other possible applications would be for connections to external power supplies via user-installed rear panel binding posts, or to connect two or more pathways to a given socket terminal (for Kelvin connections, for example).

In order to gain access to the circuit board for modification, you must first remove the sub chassis from the test fixture, as described in paragraph 3.4. Then, the module shield must be removed to gain access to the circuit board.

**WARNING**

Disconnect all other equipment from the test fixture before removing the sub chassis and shield.

**CAUTION**

Be careful not to touch board surfaces other than around the area you intend to modify. Otherwise, surface contamination may affect measurement integrity.

To customize a particular socket pin connection, first cut the circuit board trace for the pathway you are modifying adjacent to the socket terminal using a sharp knife or razor blade (be careful not to cut the surrounding guard

traces, however). After cutting the trace(s), scrape away any solder resist or oxidation, then solder the components or wires, directly to the traces or the ZIF socket pins.

After soldering, carefully clean the flux from the board using Freon® TE or TMS, then use a cotton swab dipped in clean methanol, being careful not to spread the flux to other areas of the board. After cleaning, blow dry the board with nitrogen gas, then allow it to dry for several hours in a 50°C low-humidity environment before use.

### 3.7 BINDING POST INSTALLATION

Supplied binding posts can be installed in the 3/8" holes in the rear panel as discussed below. These binding posts can be used for such purposes as routing power supply voltages to the device sockets without having to use the triax signal paths, or routing wires between the lid and fixture base.

#### WARNING

Maximum test fixture signal level is 200V, 1A peak. Exceeding these levels may create a shock hazard.

#### 3.7.1 Supplied Binding Posts

Supplied binding posts are summarized in Table 3-3. All posts are identical except for color.

#### WARNING

When using hazardous voltages (>30V RMS) with binding posts, use the following precautions:

1. Turn off all sources before connecting.
2. Dress leads so that no conductive surfaces are exposed after connection.
3. Use the safety interlock circuit.

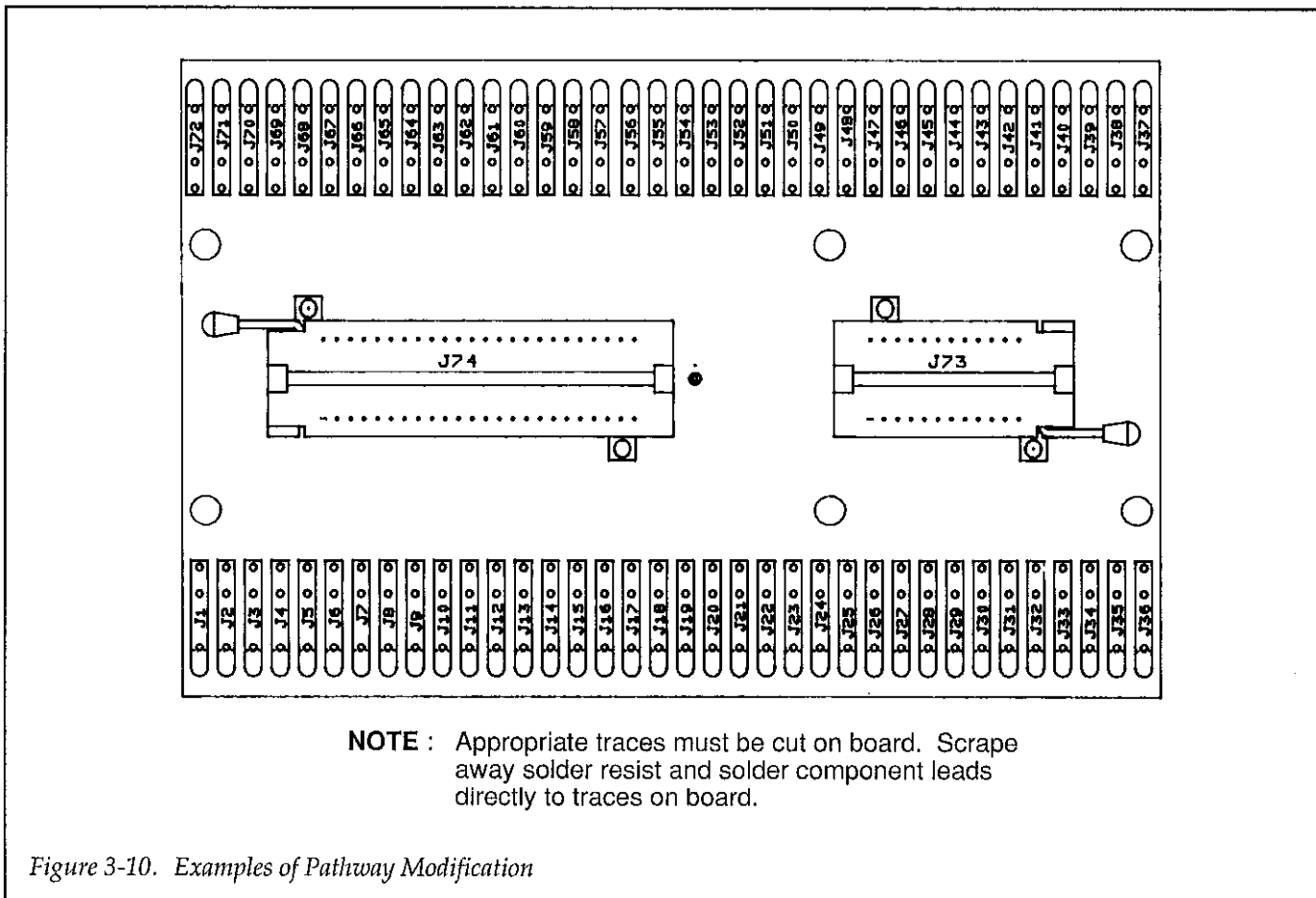

Figure 3-10. Examples of Pathway Modification

Table 3-3. Supplied Binding Posts

Keithley Part No.	Color
BP-11-0	Black
BP-11-2	Red
BP-11-5	Green
BP-11-6	Blue
BP-11-9	White

### 3.7.2 Installation Procedure

**WARNING**

Turn off all power and disconnect all cables from the test fixture before removing the sub chassis.

1. Remove the sub chassis from the test fixture by first removing the screws that secure the sub chassis to the fixture (see Figure 3-5).
2. Remove the plugs from the 3/8" holes into which binding posts are to be installed.

**WARNING**

Do not leave any open holes, which could result in a possible shock hazard.

3. Install the binding post(s) in the hole(s) using Figure 3-11 as a guide. Once assembled, secure the post with the small washer and nuts. Solder the wire(s) to the tip of the binding post, or install a lug on the end of each wire, and secure the lug with a nut on the lug post.

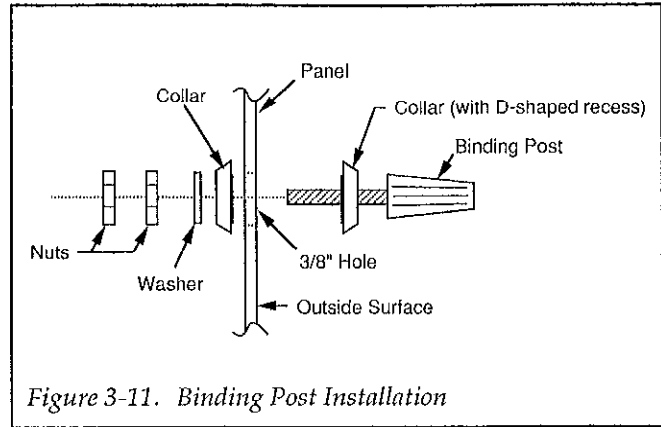

### 3.7.3 Binding Post Wiring

After installation, the binding posts can be wired to the desired points on the test fixture circuit board. For example, you may wish to connect these posts to specific socket terminals for power supply routing. All wiring must have a 200V, 1A peak rating to conform to the ratings for the test fixture.

To wire to the circuit board, first cut the trace adjacent to the socket terminal, then scrape the resist off the surface of the trace. Solder the wire end directly to the trace, taking care not to short out to adjacent traces. Clean the circuit board after soldering.

Figure 3-7 shows how to make connections to the circuit board in detail.

### 3.7.4 Sub Chassis Installation

After the binding posts are wired and connected, the sub chassis should be installed and secured with the six screws removed earlier. Also, be sure to connect the SUB CHASSIS and CHASSIS (MEASURE) posts together with the shorting link unless you intend to guard the sub chassis (see paragraph 2.2.3 for details on guarding the sub chassis).



# SECTION 4

## Replaceable Parts

---

### 4.1 INTRODUCTION

This section contains a list of replaceable parts for the Model 8007 as well as a component layout drawing and schematic diagram of the test fixture.

### 4.2 PARTS LIST

Table 4-1 summarizes parts for the Amp connector that mates with the I/O connectors on the test fixture. This information is included for those who wish to construct their own custom connecting cables. Parts for the Model 8007 Test Fixture are listed in Table 4-2.

**Table 4-1. Mass-terminated Connector Parts List**

Description	Amp Part Number
Signal Socket	66101-4
Coaxial Socket	51565-1
Ferrule	1-332056-0
Housing (plug)	201355-0
Hand Tool*	69656
Die Set*	69690

NOTE: Listed parts are for mating connector to I/O connectors on Model 8007.

\*These tools are recommended for crimping coaxial connectors onto cables. Recommended coax: RG-174.

### 4.3 ORDERING INFORMATION

To place an order, or to obtain information about replacement parts, contact your Keithley representative or the factory (see the inside front cover of this manual for addresses). When ordering parts, be sure to include the following information:

1. Test fixture model number (8007)
2. Test fixture serial number
3. Part description
4. Circuit designation, if applicable
5. Keithley part number (see parts list)

### 4.4 FACTORY SERVICE

If the test fixture is to be returned to Keithley Instruments for repair, perform the following:

1. Complete the service form located at the back of this manual, and include it with the unit.
2. Carefully pack the test fixture in the original packing carton or the equivalent.
3. Write ATTENTION REPAIR DEPARTMENT on the shipping label.

### 4.5 COMPONENT LAYOUT AND SCHEMATIC DIAGRAM

Figure 4-1 is the component layout for the test fixture. Figure 4-2 shows a schematic diagram of the fixture.



## MODEL 8007, PARTS LIST

DESCRIPTION	KEITHLEY PART NO.
CONN, COAXIAL SOCKET	CS-669
FASTENER (HARTWELL)	FA-218
FRONT PANEL OVERLAY	8007-313
RECEPTACLE, TEST SOCKET, 24-PIN	SO-106-1
RECEPTACLE, TEST SOCKET, 48-PIN	SO-106-3
STANDOFF	ST-139-16
UNIVERSAL ZIF TEST SOCKET, 24-PIN	SO-107-1
UNIVERSAL ZIF TEST SOCKET, 48-PIN	SO-107-3
#4-40 PEM STANDOFF	FA-217-1
#4-40 PEM STUD	FA-213-1
BINDING POST	BP-15
BINDING POST	BP-11-9
BUMPER	FE-18
CASTING, MACHINED	8007-317
CONNECTOR, 3 PIN	CS-659
FELT	GA-26
FIXED JACKSCREW, FEMALE	CS-661
FIXED JACKSCREW, MALE	CS-660
FIXED JACKSCREW, MALE	CS-660
GROUND STRAP	8007-321
HANDLE MOUNTING SCREW	FA-192
HANDLE OVERLAY	8007-318
HINGE	H-6
INSULATOR	27493-15
INSULATOR PANEL	8007-305
MODULE CAGE	8007-304
PIN HOOD	CS-685
PIN HOOD	CS-685
REAR SUBPANEL	8007-306
TOP COVER	8007-310
#2 LOCKWASHER	2LKWA
#4 PEM NUT	FA-103
#4 PEM NUT	FA-103
#4 PEM NUT	FA-103
#4 PEM STUD	FA-140-5
#4-40 PEM STUD	FA-213-2
#6 KEPNUT	6-32KEPNUT
#6 PEM STUD	FA-53
#6-32 PEM NUT	FA-18
#8 PEM NUT	FA-23
FIXED JACKSCREW, FEMALE	CS-661
HANDLE	HH-35
HOLE PLUG	HP-21
MODULE COVER	8007-308

NUT BAR	8007-322
NUT BAR	8007-320
REAR PANEL / BOTTOM COVER	8007-302
SHORTING LINK	BP-6
SWITCH	SW-477
SWITCH BRACKET	8007-312
#4 KEPNUT	4-40KEPNUT
#4 PEM NUT	FA-103
FRONT PANEL ASSEMBLY	8007-170
TERMINAL, MALE	CS-329
TERMINAL, FEMALE	CS-328
LUG	LU-99-3
CONNECTOR	CS-326-2

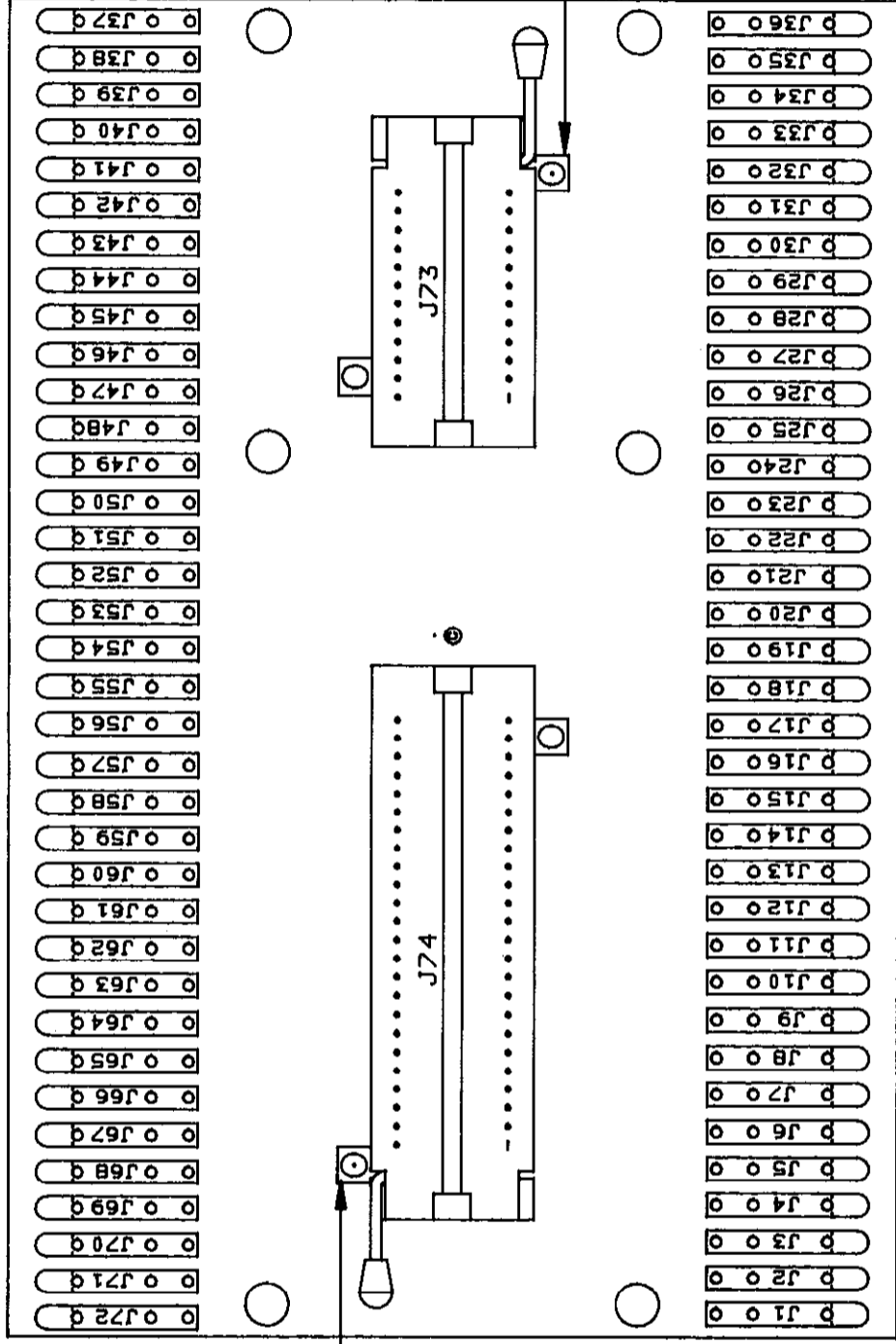

S0-106-3  
2-56x5/16PPH  
2LKWA  
2-56NUT

8007-102

S0-106-1  
2-56x5/16PPH  
2LKWA  
2-56NUT

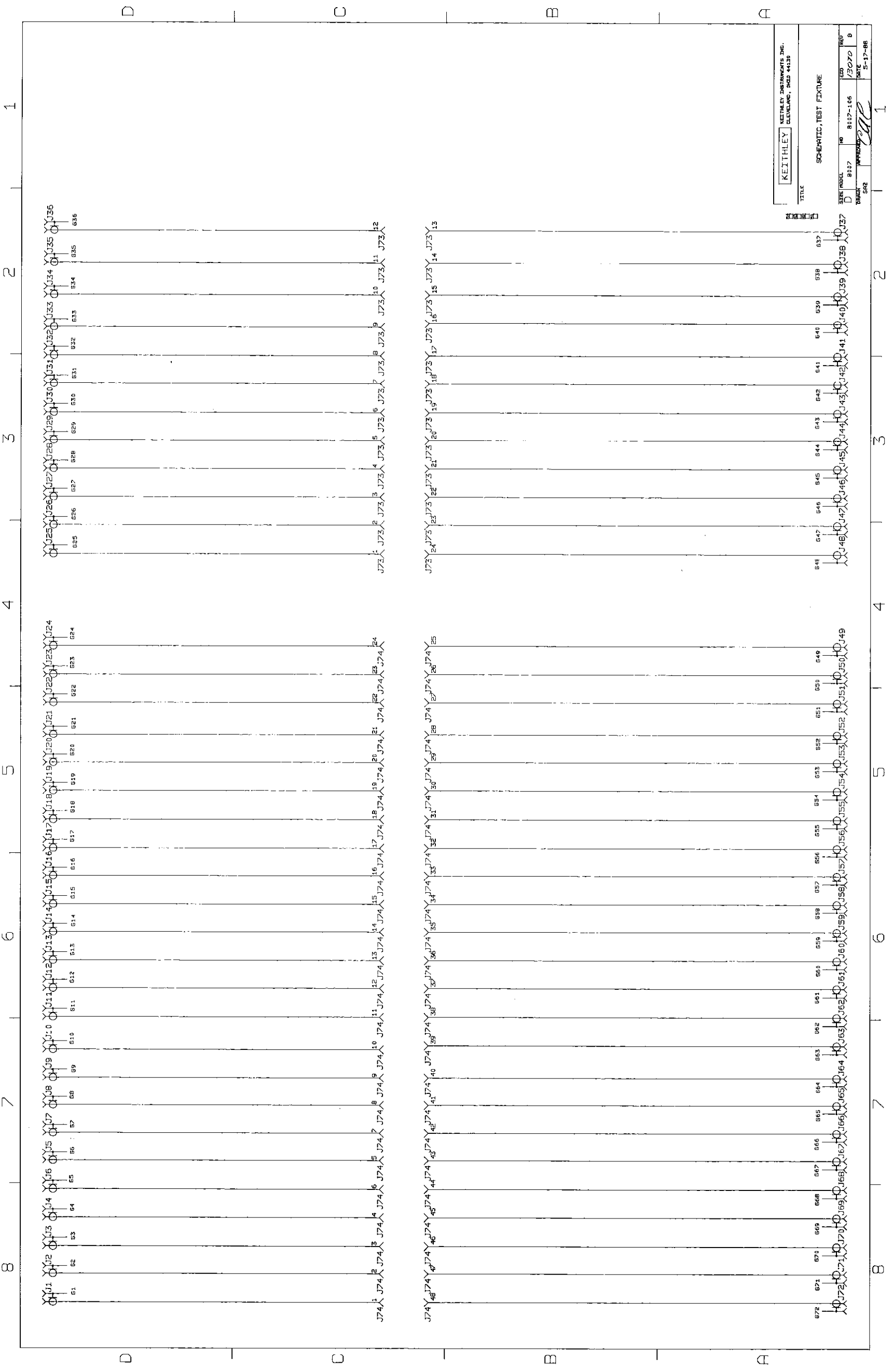

KEITHLEY INSTRUMENTS INC.  
 CLEVELAND, OHIO 44136  
 TITLE  
 SCHEMATIC TEST FIXTURE  
 DRAWING NO. 8107-106  
 DATE 5-17-88  
 REVISION 1

# Appendix A

## Bibliography of Semiconductor Measurements and Related Topics

---

Coyle, G. et al Switching Handbook. Keithley Instruments., Cleveland, (1987).

Grove, A.S., Physics and Technology of Semiconductor Devices. Wiley, New York (1967).

Nicollian, E.H. and Brews, J.R. MOS Physics and Technology. Wiley, New York (1982).

Sze, S.M. Physics of Semiconductor Devices, 2nd edition. Wiley, New York (1985).

Sze, S.M. Semiconductor Devices, Physics and Technology. Wiley, New York (1985).



# SERVICE FORM

Model No. \_\_\_\_\_ Serial No. \_\_\_\_\_ Date \_\_\_\_\_

Name and Telephone No. \_\_\_\_\_

Company \_\_\_\_\_

List all control settings, describe problem and check boxes that apply to problem. \_\_\_\_\_

- Intermittent                       Analog output follows display       Particular range or function bad; specify \_\_\_\_\_
- IEEE failure                         Obvious problem on power-up       Batteries and fuses are OK
- Front panel operational       All ranges or functions are bad       Checked all cables

Display or output (circle one)

- Drifts                                       Unable to zero
- Unstable                                 Will not read applied input
- Overload

- Calibration only                       C of C required
- Data required

(attach any additional sheets as necessary.)

Show a block diagram of your measurement system including all instruments connected (whether power is turned on or not). Also, describe signal source.

Where is the measurement being performed? (factory, controlled laboratory, out-of-doors, etc.)

\_\_\_\_\_

What power line voltage is used? \_\_\_\_\_ Ambient Temperature? \_\_\_\_\_ °F

Relative humidity? \_\_\_\_\_ Other? \_\_\_\_\_

Any additional information. (If special modifications have been made by the user, please describe.) \_\_\_\_\_

\_\_\_\_\_

Be sure to include your name and phone number on this service form.